

GE
Sensing & Inspection Technologies

Rigid Borescope

Remote Visual Inspection

Precision Optics
Durable Construction
Cost Effective



Inspection Solutions

People buy our Remote Visual Inspection products because they either have a problem, think they have a problem, or need to know there isn't a problem. We try to provide the solution to these questions with images from deep inside structures, turbine and reciprocating engines, aircraft, machines and products of all kinds. We offer you the most cost-effective solution to your inspection problem.

In our core business of Remote Visual Inspection, we offer a complete portfolio of equipment including Rigid Borescopes, Industrial Fibrescopes, Industrial VideoProbe® systems, CCD cameras and related products for video documentation and photography.

GE Sensing & Inspection Technologies' industrial Rigid Borescopes set the standard for image quality and durability in Remote Visual Inspection equipment. The range includes Rotascope Rigid Borescopes with rotatable insertion tubes, Swing-prism Rigid Borescopes with variable directions-of-view and Mini-rigid Borescopes, all with fiber-optic illumination.

Additional Rigid Borescopes, with conventional lamp illumination at the tips, include the low-cost Econoscope, in 9.0 mm (0.35 in.) and 6.5 mm (0.25 in.) diameters, while the TEW Extendible Rigid Borescopes come in 9.0 mm (0.35 in.), 14.0 mm (0.55 in.), 18.0 mm (0.70 in.) and 24.0 mm (0.95 in.) diameters.



Aircraft Engine Inspection

Contents

- 1 Inspection Solutions
- 2 Rigid Borescopes
- 3 Rotary Scan™ Rigid Borescopes
- 4 Hardware Features
- 5 Rigid Borescopes
- 6 Swing-prism Rigid Borescopes
- 7 Mini-rigid Borescopes
- 8 Specifications
- 9 Light Sources and Accessories
- 10 Rigid Borescope Video System



Steel wall-tie inside brick cavity wall

Structural surveying with fully portable ELS-24DC KIT, light source and battery pack.



Rigid Borescopes

Precision Optics

GE Rigid Borescopes feature precision lenses, prisms and cover-glasses that deliver bright, clear images. The use of a special penta-prism at the tip ensures correct image orientation without the need for a compensating dove-prism.

Special attention to maximizing light transmission in the optical path results in increased image brightness, and the on-axis resolution at the image center is held as high as possible towards the edge of the field of view. This uniform, flat field makes the smallest defects visible, and greatly reduces user eyestrain.

Diameter and Length Options

Standard range Rigid Borescopes are available in diameters 4.0 mm (0.15 in.), 6.0 mm (0.24 in.), 8.0 mm (0.31 in.) and 10.0 mm (0.39 in.).

The standard range is available in working lengths from 100.0 mm (3.94 in.) to 905.0 mm (35.63 in.).

There are five choices of direction-of-view (DOV) and, on some diameters, three different fields-of-view (FOV) can be specified.

Superior Illumination Performance

By bringing the illumination fibers close to the viewing window at the distal tip, in a “wrap-around” arrangement, the parallax between illumination and optical fields is virtually eliminated, considerably reducing the closest illuminated viewing distance.

All GE Rigid Borescopes are designed to correctly illuminate the entire field-of-view, right down to their minimum focusing distance.

Tip Length

Unique tip design with shortest tip length and wrap around fibers

Typical Design

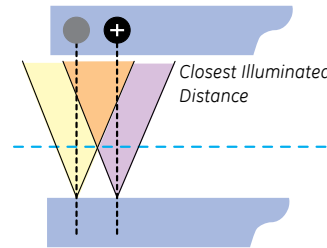

GE Design

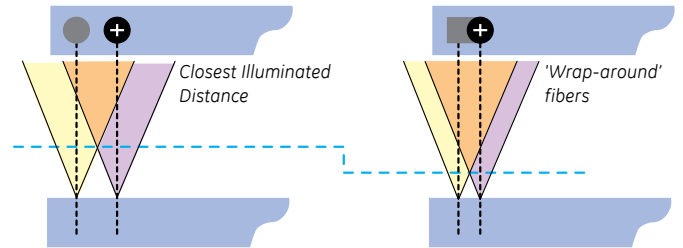

Rigid Borescope inspection of power take-off transmission



Rigid Borescope with ELSV-60



Close-up view of helical-cut gear and pinion

Rotary Scan™ Rigid Borescopes

GE's Rotary Scan™ Rigid Borescope allows 360° rotational viewing without moving the body of the scope.

Tip Length and Chisel-tip Design

The “wrap-around” fiber arrangement reduces the tip length of the oblique, lateral and retro-view instruments to an absolute minimum.

With the 45° and 70° direction-of-view instruments, the distal tip is wedge-shaped, like a chisel, allowing the Rigid Borescope to provide clear views to the bottom of blind holes. A typical example would be to view the roots of turbine blades with greater clarity.



Turbine inspection

Direction-of-view (DOV)

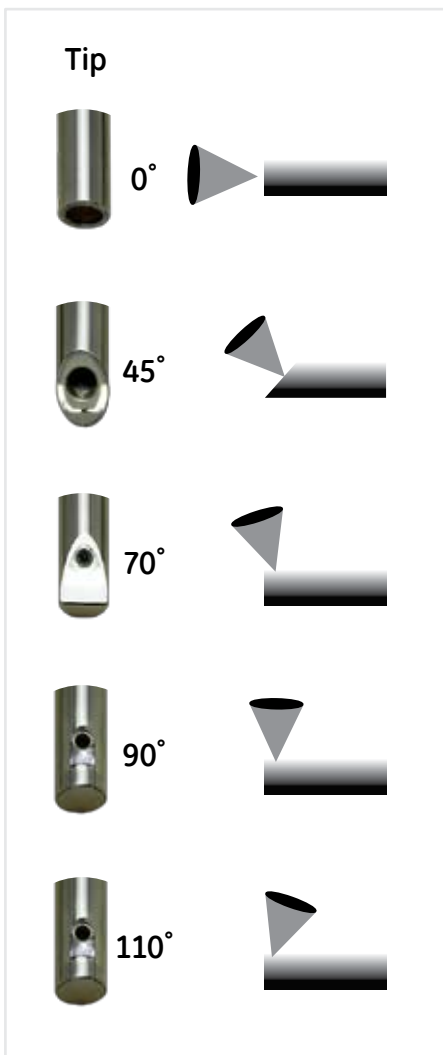

Field-of-view (FOV)



The 90° field-of-view, shown at the far left, produces the lowest magnification. The 60° and the 35° field-of-view provide increasingly greater magnification.

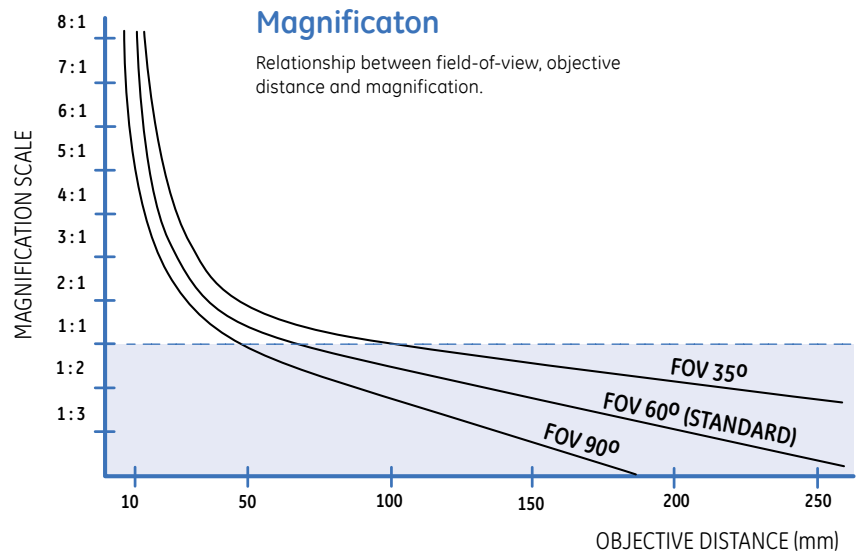

Hardware Features

Rugged Construction

GE Rigid Borescopes are specifically designed to meet the demands of harsh industrial environments, with all-metal construction, triple-tube shafts and durable hard-anodized aluminum bodies.

Triple-Tube Insertion Shaft

The insertion tube assembly consists of a double-walled stainless steel tube surrounding illumination fibers and the optical cover-glass. Fuel, oil and watertight, this sealed outer-tube assembly is pressure tested during the manufacturing process to protect the prism and lens system, which is assembled separately and fitted inside. In addition to protecting the precision optical components, this design also permits easy disassembly for service and repair.

All-Metal Body

An anodized aluminum body provides a secure and rugged location for the rotatable insertion tube and the ocular eyepiece.



360° Rotary Scan

The insertion tube of the Rigid Borescope can be rotated, allowing the viewing field to be scanned 360° (with overlap from field-of-view) without moving the body of the borescope. A positive stop is built into the body to prevent over-rotation of the lighting fibers.

Viewing Direction Indicator

When inspecting inside a closed cavity or inspection area, the tip of the Rigid Borescope might not be visible to the operator and it can be difficult to determine which direction is being viewed. On all Rigid Borescopes with oblique, lateral or retro directions-of-view, a raised indicator mark in the rotary scanning control allows viewing direction to be monitored by feel alone, without taking one's eye from the eyepiece.

Fiber and Bearing Life-Tested and Proven

During development testing, Rigid Borescopes were subjected to 20,000 operating cycles, stop to stop. Bearing surfaces between the insertion tube assembly and the bore of the body showed no measurable wear, and there was no loss of lighting performance due to fiber breakage.

Rigid Borescopes



Rigid Borescope Identity Code

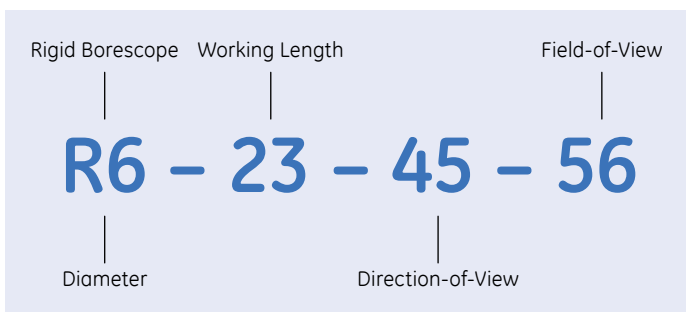

Greater Versatility

Field-of-View options: 35°, 56°, 70° and 90°

Adaptable Light Guide Fitting

All Rigid Borescopes have detachable click-on/click-off pistol grips that make them easy to handle, and protects the light-guide. The ACMI male light guide post can be converted to ACMI female / Olympus, Wolf, Storz and other pattern fittings.

Zoom Eyepiece Option

All Rigid Borescopes can be specified with a variable magnification zoom eyepiece, which gives a stepless adjustable magnification range of an additional 2:1.

When used on an instrument with a narrow field-of-view of 35°, the zoom gives similar magnification, at all viewing distances, to Rigid Borescopes with a very narrow field-of-view, but without the decreased depth-of-focus associated with such instruments. This capability is particularly valuable when the image plane is neither flat nor perpendicular to the axis of the instrument.

The super-large exit lens of the zoom ocular delivers images that are big, bright and very easy to view.



Inspection of hard-to-reach area of airframe structure

Swing-Prism Rigid Borescopes

GE's Swing-prism Rigid Borescope can fulfill the function of two or three separate conventional borescopes, reducing costs and inspection time. You can adjust the direction-of-view from 55° to 115° and scan an object's entire length.

Swing-prism Rigid Borescope with Rotation and Zoom Ocular

Swing-prism Rigid Borescopes come with variable direction-of-view, a focusing device, rotatable objective tube and an optional variable magnification zoom eyepiece. Providing the capability to view steplessly in a range of directions, from 55° forward-oblique to 115° retro-view, one instrument can function in the place of two or three separate conventional Rigid Borescopes.

This multiple viewing capability is further enhanced by the rotatable insertion tube, which provides 340° of rotation stop-to-stop. (360° effective viewing with overlap from field-of view)

This versatility allows the same scope to be used for multiple applications and reduces inspection time by removing the need to stop the inspection to change scopes.

GE Swing-prism Rigid Borescopes are available in three diameters, 6.0 mm (0.24 in.) 8.0 mm (0.31 in.) and 10.0 mm (0.39 in.). On all models, two alternative fields-of-view are available, the standard 56° FOV being supplemented by an optional narrow-angle 35° FOV, giving higher magnification.

An optional variable magnification zoom eyepiece can be selected on the 8.0 mm (0.31 in.) and 10.0 mm (0.39 in.) instruments, making the Swing-prism Rigid Borescope one of the most versatile Rigid Borescopes around, offering variable direction-of-view, variable focus, variable magnification and circumferential rotary scanning.



RZ Swing-prism Rigid Borescope with rotatable insertion tube, variable direction-of-view and variable magnification zoom ocular

Swing-prism

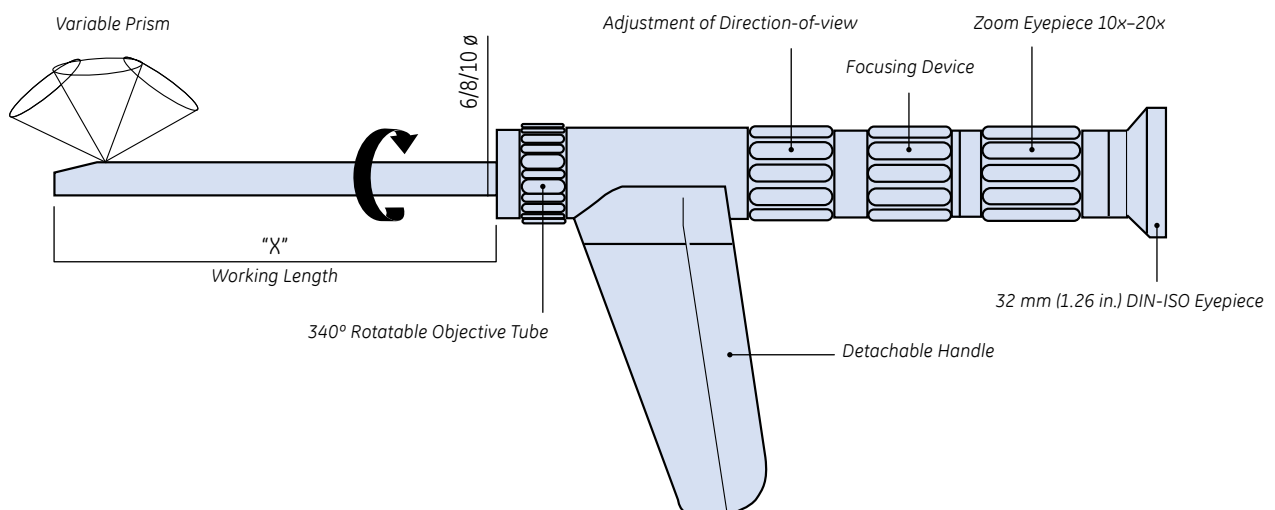
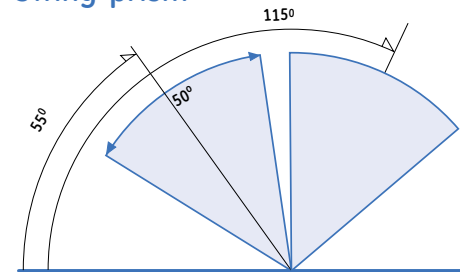

Mini-Rigid Borescope

GE's Mini-Rigids are uniquely constructed to make them more tolerant of accidental bending than conventional small-diameter Rigid Borescopes – without compromising image quality.

Main Features

- Outer tube, body and light-guide connection made of stainless steel.
- Light condenser funnel of clad-glass provides 30-percent more light output at the tip.
- Light-guide post is convertible to ACMI male or female, Wolf or Storz by means of screw-on adapters.
- Eyepiece is the DIN standard 32 mm (1.26 in.) diameter pattern and made from a high-temperature resistant durable plastic.
- Triple-tube construction on the 1.9 mm (0.75 in.) and 2.7 mm (0.11 in.) mini-rigids protects the Rigid Borescope's lens and optics, while keeping them accessible for easy service and repair.
- Patented short rod-lens optical system provides outstanding image brightness and depth-of-field from 1.0 mm (0.04 in.) to infinity.
- Wide-angle field-of-view is ideal for inspecting large surface environments.
- Resistant to fuels, oils, all common industrial solvents and water.

Short Rod-lens System

This patented system improves on the best optical features of the rod-lens system, with better tolerance to mechanical stress for industrial applications.

Each rod-lens is either a two- or five-element assembly bonded together. At a lens length that is approximately 60 percent of that found in rival instruments, three lenses are used per relay length rather than two, making the borescope more flexible and able to tolerate bending loads that would crack most lenses. The system also transports a much higher aperture, which results in outstanding image brightness.

1.7 mm, 1.9 mm, and 2.7 mm diameter



Inspecting air-brake compressor after machining

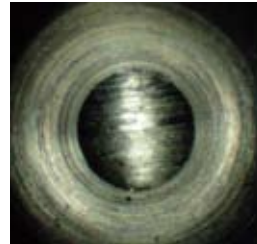

Oil-way clear and free of debris and burrs





Exceptional tolerance to bending



Specifications

Part Number	Diameter	Working Length	Direction of View	Field of View
RM17-10-30-65	1.7 mm (0.067 in.)	10.0 cm (3.94 in.)	30°	65°
RM19-10-0-65	1.9 mm (0.075 in.)	10.0 cm (3.94 in.)	0°	65°
RM19-10-30-65	1.9 mm (0.075 in.)	10.0 cm (3.94 in.)	30°	65°
RM27-14-0-80	2.7 mm (0.106 in.)	14.0 cm (5.51 in.)	0°	80°
RM27-14-70-80	2.7 mm (0.106 in.)	14.0 cm (5.51 in.)	70°	80°
R4-18-90-56	4.0 mm (0.157 in.)	18.5 cm (7.28 in.)	90°	56°
R4-21-0-56	4.0 mm (0.157 in.)	21.0 cm (8.27 in.)	0°	56°
R4-21-45-56	4.0 mm (0.157 in.)	21.5 cm (8.46 in.)	45°	56°
R4-30-90-56	4.0 mm (0.157 in.)	30.0 cm (11.80 in.)	90°	56°
R4-36-0-56	4.0 mm (0.157 in.)	36.0 cm (14.20 in.)	0°	56°
R4-36-45-56	4.0 mm (0.157 in.)	36.0 cm (14.20 in.)	45°	56°
R6-24-0-56	6.0 mm (0.236 in.)	23.5 cm (9.25 in.)	0°	56°
R6-24-45-56	6.0 mm (0.236 in.)	23.5 cm (9.25 in.)	45°	56°
R6-27-VAR-50	6.0 mm (0.236 in.)	27.0 cm (10.63 in.)	VAR	50°
R6-34-90-56	6.0 mm (0.236 in.)	34.0 cm (13.40 in.)	90°	56°
R6-44-0-56	6.0 mm (0.236 in.)	43.0 cm (16.93 in.)	0°	56°
R6-44-45-56	6.0 mm (0.236 in.)	43.5 cm (17.13 in.)	45°	56°
R6-45-VAR-50	6.0 mm (0.236 in.)	45.0 cm (17.70 in.)	VAR	50°
R6-54-90-56	6.0 mm (0.236 in.)	54.0 cm (21.30 in.)	90°	56°
R6-64-0-56	6.0 mm (0.236 in.)	63.5 cm (25.00 in.)	0°	56°
R6-64-45-56	6.0 mm (0.236 in.)	63.5 cm (25.00 in.)	45°	56°
R8-14-90-56	8.0 mm (0.315 in.)	14.0 cm (5.51 in.)	90°	56°
R8-23-VAR-50	8.0 mm (0.315 in.)	23.0 cm (9.06 in.)	VAR	50°
R8-24-0-56	8.0 mm (0.315 in.)	23.5 cm (9.25 in.)	0°	56°
R8-28-70-70	8.0 mm (0.315 in.)	27.5 cm (10.83 in.)	70°	70°
R8-28-90-56	8.0 mm (0.315 in.)	27.5 cm (10.83 in.)	90°	56°
R8-34-90-56	8.0 mm (0.315 in.)	34.0 cm (13.40 in.)	90°	56°
R28-40-VAR-50	8.0 mm (0.315 in.)	40.0 cm (15.70 in.)	VAR	50°
R8-44-0-56	8.0 mm (0.315 in.)	43.5 cm (17.13 in.)	0°	56°
R8-45-70-70	8.0 mm (0.315 in.)	44.5 cm (17.52 in.)	70°	70°
R8-45-90-56	8.0 mm (0.315 in.)	44.5 cm (17.52 in.)	90°	56°
R8-54-90-56	8.0 mm (0.315 in.)	54.0 cm (21.30 in.)	90°	56°
R8-57-VAR-50	8.0 mm (0.315 in.)	57.0 cm (22.40 in.)	VAR	50°
R8-64-0-56	8.0 mm (0.315 in.)	63.5 cm (25.00 in.)	0°	56°
RZ10-21-0-56	10.0 mm (0.394 in.)	21.0 cm (8.27 in.)	0°	56°
RZ10-22-45-56	10.0 mm (0.394 in.)	21.5 cm (8.46 in.)	45°	56°
RZ10-32-90-35	10.0 mm (0.394 in.)	32.0 cm (12.60 in.)	90°	35°
RZ10-32-90-56	10.0 mm (0.394 in.)	31.5 cm (12.40 in.)	90°	56°
RZ10-41-0-60	10.0 mm (0.394 in.)	41.0 cm (16.10 in.)	0°	60°
RZ10-42-45-56	10.0 mm (0.394 in.)	41.5 cm (16.34 in.)	45°	56°
RZ10-49-VAR-50	10.0 mm (0.394 in.)	49.0 cm (19.30 in.)	VAR	50°
RZ10-57-90-60	10.0 mm (0.394 in.)	56.5 cm (22.24 in.)	90°	60°
RZ10-61-0-60	10.0 mm (0.394 in.)	61.0 cm (24.02 in.)	0°	60°
RZ10-62-45-56	10.0 mm (0.394 in.)	61.5 cm (24.21 in.)	45°	56°
RZ10-69-VAR-50	10.0 mm (0.394 in.)	69.0 cm (27.20 in.)	VAR	50°
RZ10-81-0-56	10.0 mm (0.394 in.)	81.5 cm (32.09 in.)	0°	56°
RZ10-90-90-60	10.0 mm (0.394 in.)	90.5 cm (35.63 in.)	90°	60°

-  Mini-Rigid Borescope
-  Swing-Prism Rigid Borescope

- Operating Temperature:** -40° to 121° C (-40° to 249° F)
- Pressure Resistance:** 3 Bar (44 psi.)
- Fluid Resistance:** Insertion Tube will withstand immersion in aviation fuel, kerosene, gasoline, diesel fuel, mineral and synthetic lubrication oils and hydraulic fluids, most industrial solvents and water
- Body Length:**
 - R: 95 mm (3.75 in.)
 - RZ: 160 mm (6.4 in.)
 - PR: 140 mm (5.5 in.)
 - RZ: 200 mm (7.8 in.)
 - RM: 50 mm (2.0 in.)

Specifications subject to change without notice.

Light Sources & Accessories

GE rigid borescopes are ideal for documentation and recording images, and with the appropriate adapter, can be used with conventional and digital cameras as well as color video cameras.

The following documentation accessories are available:

- Adapters for coupling all kinds of cameras.
- Video Cameras for recording and documentation
- Monitors for displaying enlarged images.
- Light Sources

Glass fiber optic cables and liquid light-guide cables from GE are available in various lengths, with interchangeable end-fittings that allow connection to borescopes and light sources from other manufacturers.

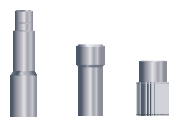

Borescope adapter suitable for light guides from Olympus, Wolf and Storz



Light guide adapter suitable for borescopes from Olympus, Wolf and Storz

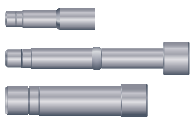

Adapters for connection to various light sources

For Rigid Borescope work where headroom is limited or access is difficult, different angle viewing attachments and an X2 magnification attachment provide a better view.



Angle Attachment 90°
(115, 300 and 1065 mm lengths)



Angle Attachment with 360° articulation

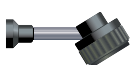

Angle Attachment 45°
(115 and 300 mm lengths)



Magnification Attachment X2

All GE Rigid Borescopes and accessories are ideal for documenting and recording images and with the appropriate adaptor, can be used with conventional and digital cameras, as well as color video cameras. This is a key option to consider when quality control is critical, or to make simultaneous viewing by more than one person possible.



XLG3™
Borescope
Adapter*

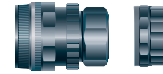

Photo Coupler Lens or
Universal Photo Adapter



Digital
camera



Universal Photo Adapter



C-mount Color
Video Camera



C-mount Video Coupler
(with fixed or adjustable focus)



High Resolution
Monitor



Mini DV Digital Video
Recorder/Monitor.
(versions with still image
grab)

* Couple any GE rigid borescope to the XLG3 VideoProbe® system to allow use of image capture and data management.



ELSV-60

60 W metal-halide light source with integral camera power and video output channel.



ELS-24DC

24 W metal-halide light source with high output and high color temperature.

Available with portable operation pouch including battery and charger (ELS-24 DC KIT)



ELSX-300

300 W Xenon light source with high output, and high color temperature.



ELS-120UV or FLS-200UV

Switchable UV/visible light sources

Rigid Borescope Video System

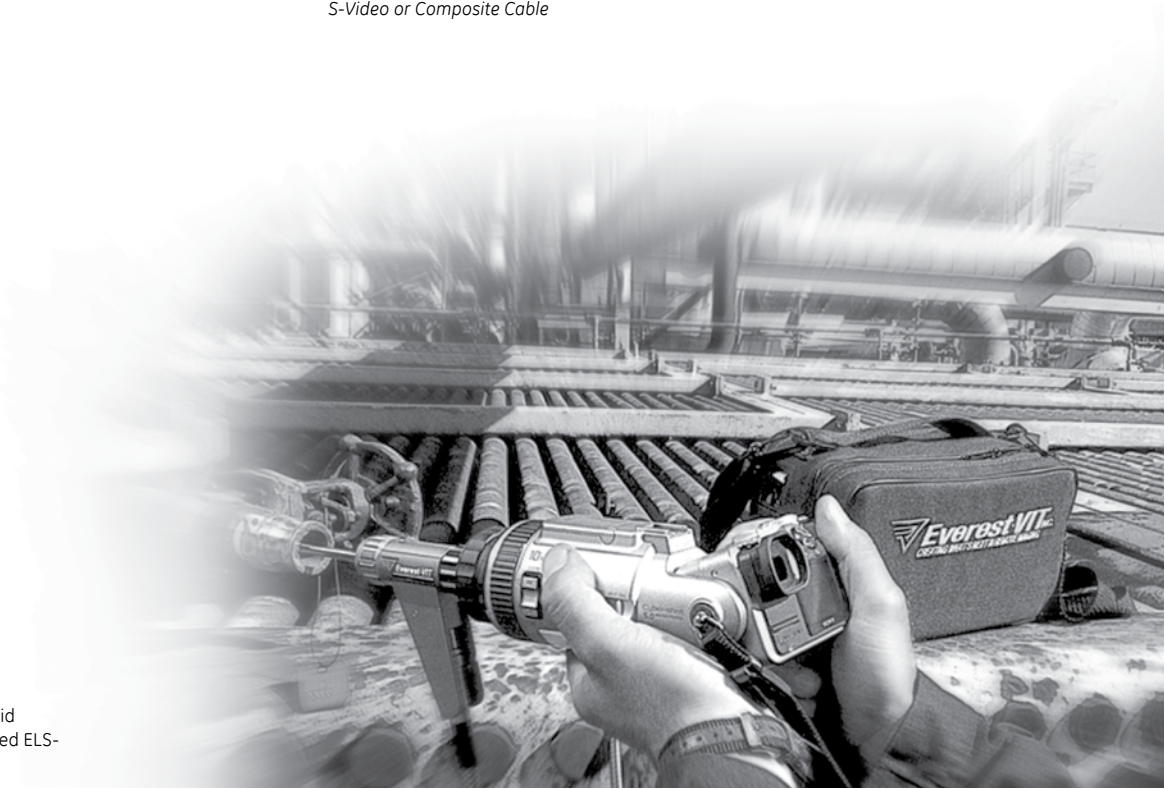
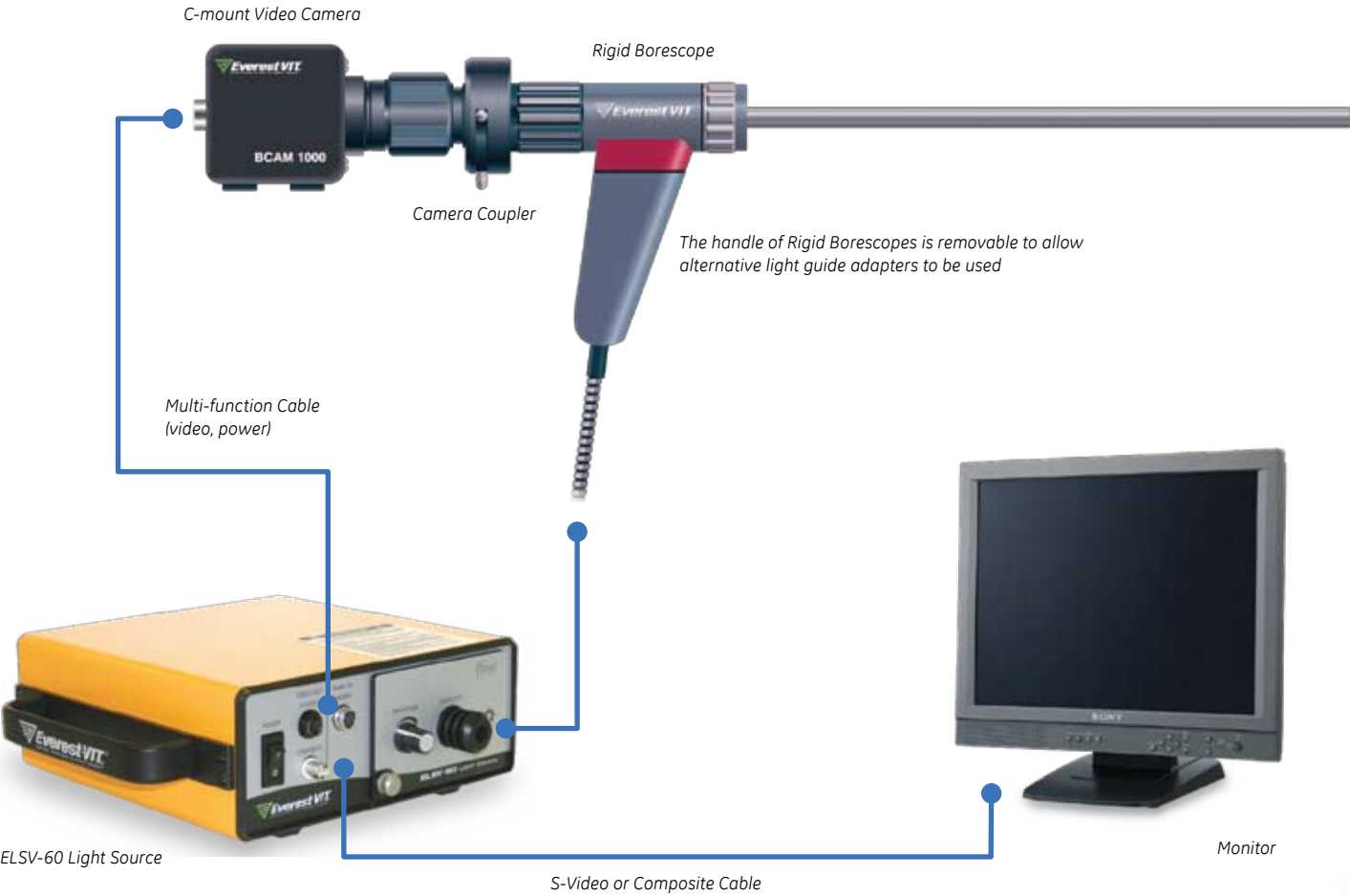

Digital photography with a Rigid Borescope and battery-powered ELSV-24DC light source



www.geinspectiontechnologies.com



GEIT-65021EN (08/08)