

SEIFERT

ISOVOLT Mobile 160

Mobile Industrial Radiography



Reliable
Flexible
Handy

ISOVOLT Mobile 160

The **ISOVOLT Mobile 160** represents the latest generation of ISOVOLT Mobile technology. Its evolution has relied upon continuous assessment of the field performance of the ISOVOLT Mobile range and it incorporates a range of features which offer demonstrable benefit in terms of:

- **Mobility**
- **Performance**
- **Versatility and Flexibility**
- **Ease-of-use**

Features Benefits

Mobility

- Combines features of stationary systems (compact tube-housings, dual-focus, mini-focus, performance) with excellent mobility characteristics
- Very compact dimensions with balloon tires:
 - Width: 615 mm
 - Weight: 145 kg (with 10 m cable)
- Can be transported horizontally
- Cart equipped with integral metal lifting eyelet
- Integrated autonomous cooling circuit

- Can be used in applications that cannot be solved by purely portable / stationary devices
- Excellent handling characteristics in narrow spaces or applications affording limited access
- Allows easy transport over stairs or loading / unloading into vans
- Supports crane lifts to difficult accessible positions
- Requires only power supply for field operation

Performance

- Constant Potential Technology, with excellent Power Rating of 1600 W @ max. 10 mA
- Power mode and Dual Focus operation
- Operation with 100% duty cycle @ 30°C (water cooler on-board)
- Real-time-clock-based fully automatic warm-up

- Generates stable penetration power and provides higher material penetration
- Minimizes exposure times and improves imaging contrast (also for double-wall inspections)
- Contributes to high performance / productivity ratio under harsh conditions
- Prolongs tube life time, increases productivity in daily inspection routine

Versatility and Flexibility

- Set-up configurable with different HV cable lengths
- Set-up configurable with different tube types. Two tubes can be pre-configured and activated
- Removable control module
- Protection for HV cable and water-hose

- A light and modular generator set, capable of reaching locations of normally difficult access
- Extends the range of potential applications
- Can be operated remotely
- Increases cable life, reduces operational wear, facilitates cable winding

Ease-of-Use

- New Graphical User Interface, featuring:
 - On-board exposure calculator
 - Monitoring and display of several parameters (temperatures, mains voltage)
 - Programming and reporting features
 - Around 20 languages, 5 character sets
 - Focal spot-selector
 - Tube database
 - Active tubes stored on slot A / slot B
 - Automatic filament current calibration

- Intuitive and safe operation

System Components

Generator

The ISOVOLT Mobile 160 industrial X-ray unit is the ideal solution for mobile radiographic testing.

The mobile transport cart, with its dimensions designed for narrow paths and passages (door frames), serves as the basis for the extremely flexible X-ray generator that can operate 160 kV insert tubes of various technical specifications.

The special design not only combines all relevant assemblies such as the control unit, water cooler, generator, tube and high voltage cable in one compact device, but also offers protection for the components in rough daily use.

High voltage cables and cooling hoses are protected by a robust canvas cover. It helps with safe handling and simplifies transport.

An additional crane eye on the transport cart also extends the range of application of the ISOVOLT Mobile 160 for work at heights, whereby the device can then be transported to hard-to-reach places using a crane. The start/stop function can also be carried out via an optionally available remote control.

A large number of X-ray tubes are available for the different applications. The portfolio includes high-power and mini-focus tubes as well as panoramic exposure tubes and special tubes with small dimensions.

High voltage cables are available in increments of up to 20 meters in length and allow the device to be configured individually for use in such a way that the test task can be carried out with maximum benefit and minimal effort.



Control Module

The ISOVOLT Mobile 160 is equipped with a modern control unit which, in addition to an ergonomic design with a user-friendly graphic display, keeps menu-supported operation simple. The transfective property of the display enables a reliable reading of the parameters both in unfavorable sunlight and with background lighting in the dark.

The menu-based user guidance is particularly impressive in daily use. Not only does it enable quick and easy operation, it also makes work easier for the operator thanks to aids. These include the built-in exposure computer, the fully automatic run-in sequences, working with freely programmable settings for the administration of exposure programs, as well as system status displays for displaying the operating parameters and device-specific information and sub-menus for tube selection and activation.

A large number of productivity-promoting "Features on Demand" such as the optional Administrator Kit but also "Quick Select" functions such as the film-focus-distance (FFA) correction calculator that can be selected quickly complete the high level of user control.



09 Operat. history 000			
No	kV	mA	Date Time
001	M 50	0.51	0.0 27.07.2009 09:09:36
002	W 80	0.100	0.0 27.07.2009 09:09:36
003	W 80	0.100	0.0 27.07.2009 09:09:36
004	M 50	0.51	0.0 14.07.2009 10:27:26
005	M 50	0.51	0.0 14.07.2009 10:27:26
006	M 0	0.0	0.0 01.01.2000 00:00:00
007	M 0	0.0	0.0 01.01.2000 00:00:00
008	M 0	0.0	0.0 01.01.2000 00:00:00
009	M 0	0.0	0.0 01.01.2000 00:00:00

MANUAL			Measured Values
Nom	Act		
kV	50	50	24 °C
mA	5.1	5.1	25 °C
	00'00"	00'00"	25 °C

EXPOSURE CALCULATOR			
	Nom	Act	Exp. Parameter
kV	160		Material Fe
			Thickness 42.0 mm
mA	4.5		Density 2.5
			Film D7/C5
P	10'05"		FFD 700 mm
			mA x min 0.0

MANUAL		
Nom	Act	
kV	50	0
mA	5.1	0.0
I>P	20'00"	20'00"
FFD	IV 160MM2/HP	

Examples of menu and user guidance

Applications

Aerospace

During aircraft maintenance and servicing, it is often necessary to carry out radiography in very restricted spaces. The quality of images is therefore very much dependent on the inspection arrangement and requires that radiography systems are extremely flexible.

With its compact dimensions and flexible high voltage cable, the ISOVOLT Mobile 160 can be aligned easily to suit the inspection task. The unit can also be used in the very tight spaces bounded by struts and skin, as there is just 5.6 cm between the centre of the exit window and the tube. The choice of tubes is also of great benefit in this sector and the intuitive user guidance feature can help to accelerate and simplify maintenance.

The extended programming and reporting features of the ISOVOLT Mobile 160 allow it to be embedded in various documentation workflows encountered in the aerospace sector so that specific X-ray inspection information can be used for consistent reporting purposes.



Power Generation

The majority of inspection tasks in power generation relate to welds, which are fundamental to safety. Nearly always, these welds are in areas of difficult access and consequently demand a very compact design of radiography equipment. In addition the fact that a generator can also drive a panoramic tube is of great help in inspection of circumferential welds.

The compact design, pneumatic tyres, cable- and hose-sheathing, range of cable lengths and cranability also contribute to the equipments suitability for inspection of power station cooling and heat-exchanger systems.



Oil & Gas

In the oil and gas sector, radiography is carried out predominantly on welds during pipeline and vessel fabrication. In these applications, the ISOVOLT Mobile 160 helps to provide simple, fast and reliable radiography of welds and pipe sections.

By using a panoramic tube of only 100 mm diameter, the X-ray tube can be inserted into narrow vessel nozzles and can also be used for the inspection of items such as flanges. Also by using different size shutters, it is possible to carry out a wide range of inspection tasks in the oil and gas sector, saving costs and increasing productivity.



Metals

As a versatile, mobile, and universal radiography system, with dual focus and panoramic X-ray tubes, ISOVOLT Mobile 160 offers an optimum solution for weld inspection.

In shipbuilding, with wall thicknesses up to 20 mm, the ISOVOLT Mobile 160, with its compact tubes and long High Voltage cables, offers significant advantages over competitive mobile units. This is especially the case when it is used between frames in very tight ship's bodies. In addition, its water-cooling is more efficient than air-cooled systems, which significantly increases productivity and facilitates handling. These same benefits also apply to radiography in offshore platform fabrication yards.

Technical Data

High Voltage Generation

Tube voltage	5 – 160 kV (in 1 kV intervals)
Tube current range	0.5 – 10 mA (in 0.1 mA intervals)
Maximum output power	1600 W
Duty cycle (∅ ambient temperature = 30°C)	100 %
Cooling	Installed water cooler WL 2001
Maximum cooling capacity (∅ ambient temperature = 30°C)	1600 W

Operating Module

Exposure time, adjustable to intervals of 1 second or directly as min/seconds-value	1 to 5,994 seconds (optional display 99 min/99 sec), or clock deactivated for fluoroscopy operation
Pre-programmable exposure program	Maximum 250, administrable in list form, free naming of the program
Memory for operating and warm-up-events	256/128 administrable in list form
Display	Transflective, backlit graphic display, 320 x 240 pixels
Supported languages	21
Character sets	5, European (ISO), Japanese, Chinese, Cyrillic, Arabic
Exposure calculator	On-board, Fe, Ti, Al pre-programmed / Characteristics for 3 materials freely programmable
Warm up	Fully automatic, based on real time clock
Parameter monitoring	Continuous, online display of device temperatures and supply voltage
RS232 serial interface	1
Safety interlocks	2
Emergency off button	1
Keyswitch with 3 positions	OFF, STANDBY, ON
Additional functions	Change of focus, film-focus-distance correction, extended warm-up Comprehensive tube database, 2 slots for activated tubes, power mode

Ambient Conditions

Protection class	IP 54
Operating temperature range*	-20 °C to +40 °C
Storage temperature range*	-30 °C to +70 °C
	* Anti-freeze has to be used for temperatures below 5°C

Connected Loads

Power supply	1PE, 230 V +/- 10 %; 50/60 Hz; 3.0 kVA; max. 16 A
--------------	---

Dimensions

High voltage cable	10 m (optional 15 m/20 m)
Power cable	10 m
Dimensions (width x depth x height)	625 mm x 980 mm x 1285 mm
Weight	With 10 m cable 145 kg

Certifications / Standards

CE-Conformity, NFC 74100, ANSI N43.5

Dimensions

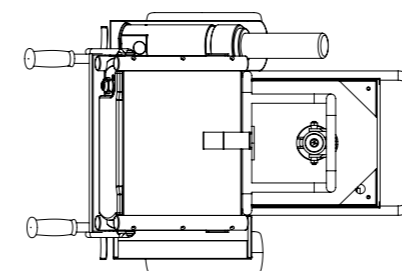
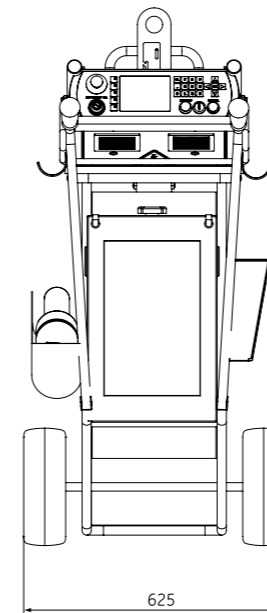
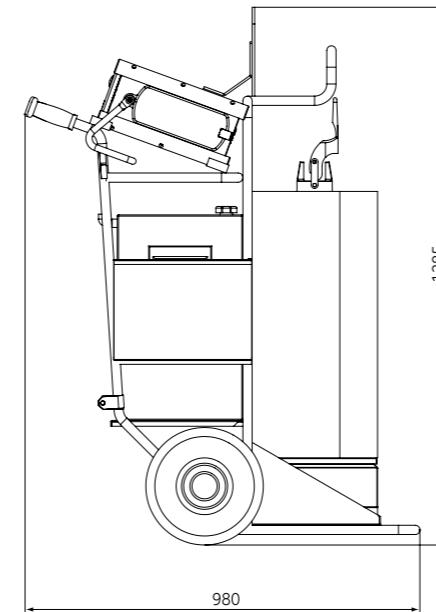

Delivery Scope

Delivery Scope

- 1 High voltage generator 160 kV
- 1 Control Unit ISOVOLT Mobile
- 1 Water cooling pump WL 2001
- 1 X-ray tube head (see selection)
- 1 High voltage cable (10 m, 15 m or 20 m long)
- 1 Protective hose for high voltage cable and water hoses
- 1 Transport cart
- 1 Set of cooling water hoses and accessories

Supported tube heads

Directional:

- ISOVOLT 160MM2/HP
- ISOVOLT 160M2/0.4-0.4
- ISOVOLT 160M2/0.4-1.5
- ISOVOLT 160M2/0.4-0.4HP
- MCD 100H-3

Panoramic:

- MCR 120A-2.5
- ISOVOLT 160MC2

Accessories

- Diaphragm and centering device
- Remote Control
- External fail-safe warning flash lamp
- External fail-safe warning blinking lamp
- Administrator Kit (including Interface cable, CD-ROM)

Waygate Technologies
Bogenstr. 41 • 22926 Ahrensburg / Germany
Tel.: +49 4102 807 0 • Fax: +49 4102 807 189 • E-Mail: xray.info@bakerhughes.com

Copyright 2020 Baker Hughes Company. This material contains one or more registered trademarks of Baker Hughes Company and its subsidiaries in one or more countries. All third-party product and company names are trademarks of their respective holders.

BHWT-30193EN (09/09)

Baker Hughes 

waygate-tech.com