

Product Information

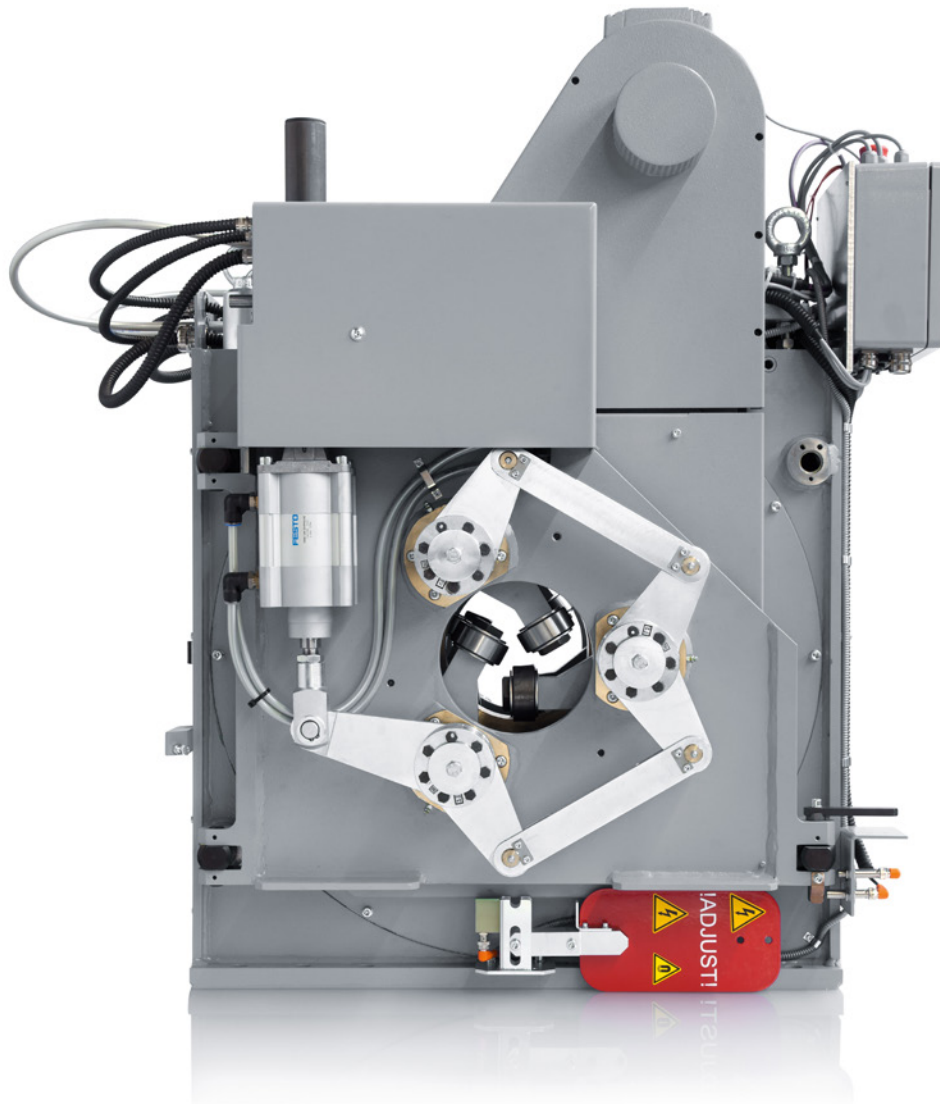

CIRCOSON® WT with Sensor System Ro 180

9.740.02-4



proof.

Index

Application	3
Operating Principle	4
Mechanical Construction	7
Testing and Evaluation Electronics	7
Sensor System	7
Rotating Head	8
Rotating Unit	8
Disc Slip Ring and Brush Blocks	9
Spacers	10
Test Heads	10
Roller Guides	12
Suction Connection	13
Specifications of the Test Material	14
Transport of the Test Material	15
In General	15
Guidance Accuracy	15
Test Speed	15
Admissible Tolerance of Test Material	16
Wall Thickness Measurement and Lamination Testing	17
Noise Level	17
Wall Thickness Measurement	17
Lamination Testing	19
Acceptance Specification	20
Requirements for the Operation of the Test Instrument	21
Performance Data	22
Testing	22
Changeover Times	22
Untested Ends	22
Marking Duration of the Color Marking	22
Further Technical Data	23
Parameters of the Ultrasound System	23
Test Heads	23
Rotating Head	23
Noise Emissions	24
Dimensions	25

Application

The CIRCOSON WT sensor system Ro 180 operates on the basis of the EMAT (Electro Magnetic Acoustic Transducer) principle. Together with the test and evaluation electronics and a suitable transport mechanism, the sensor system allows a highly accurate wall thickness measurement of ferromagnetic seamless steel tubes in accordance with API 5L and 5 CT. In this case, no coupling medium is needed. A wall thickness measurement accuracy of approximately $\pm 50 \mu\text{m}$ and a high testing speed up to 3.2 m/s with 100 % coverage of the surface is possible. By using suitable test heads, the system additionally enables lamination testing according to DIN EN ISO 10893-8.

The test material has to pass through the sensor system centrally and without vibrations. This requires a good integration into the testing line. FOERSTER offers tailored system solutions, which are developed in partnership with our customers. The sensor system Ro 180 covers the material diameter range from approximately 20 to 180 mm. Test material temperatures up to $+ 80 \text{ }^\circ\text{C}$ are permitted. The surface conditions should be bright or hot-rolled and free of loose scale and protruding burrs. A maximum straightness tolerance of 2.5 mm/m is allowed.

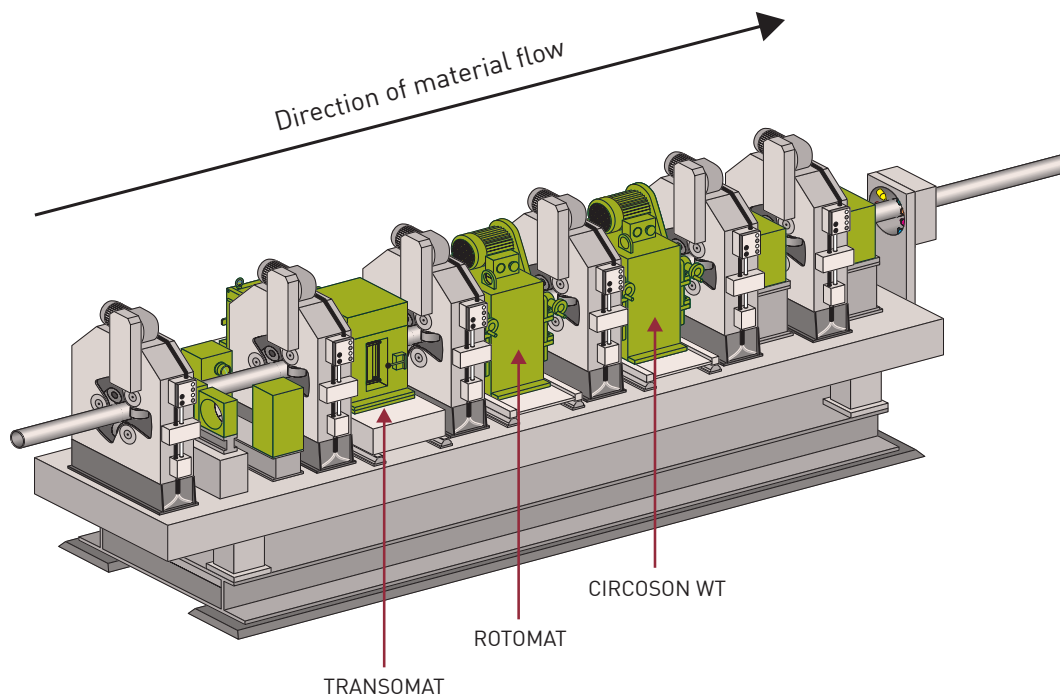

Fig. 1: Tube application of CIRCOSON WT for wall thickness measurement in combination with ROTOMAT / TRANSOMAT for Magnetic Flux Leakage testing

Operating Principle

The EMAT-Method (Electro Magnetic Acoustic Transducer) is a technology where ultrasound is created and received electro-dynamically directly in the test material, which means no coupling agent is required. The principle is described in the following.

First of all Eddy Currents are generated by a transmitter coil in the surface of the tube (see Figure 2). This is done in the presence of an adequate magnetic field. Thus Lorentz Forces appear (see Figure 3).

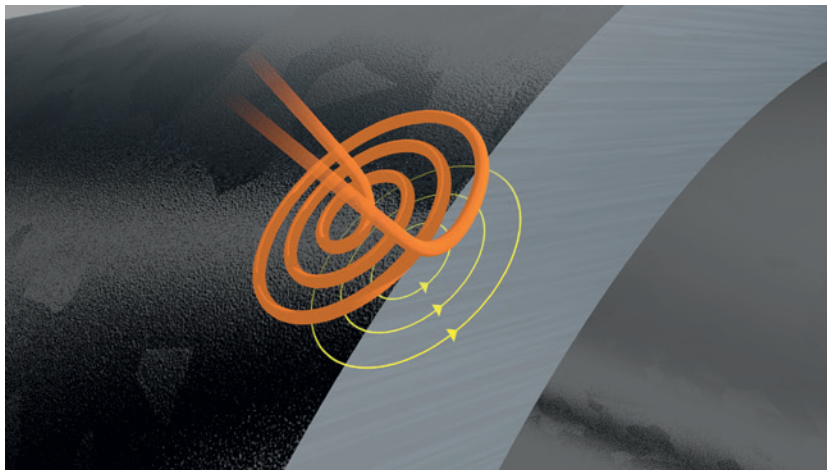

Fig. 2: Generating Eddy Currents

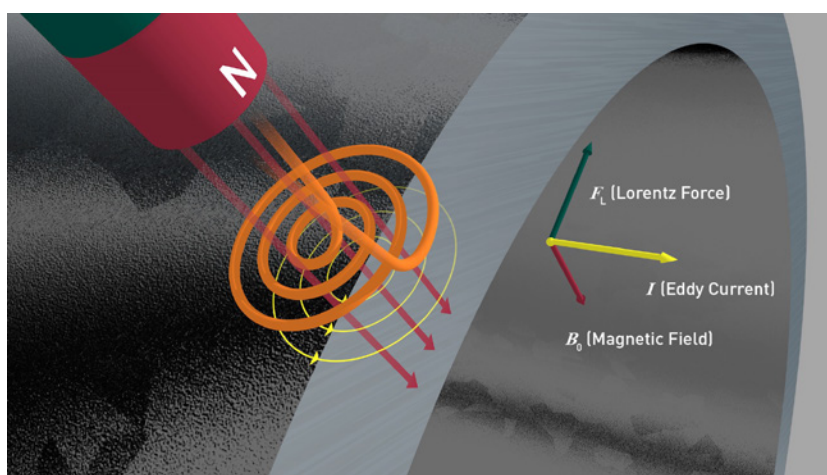

Fig. 3: Appearance of Lorentz Forces in a Magnetic Field

Periodic Eddy Currents produce periodic Lorentz Forces (see Figure 4).
 Periodic Lorentz Forces generate acoustic waves with the same frequency (see Figure 5).

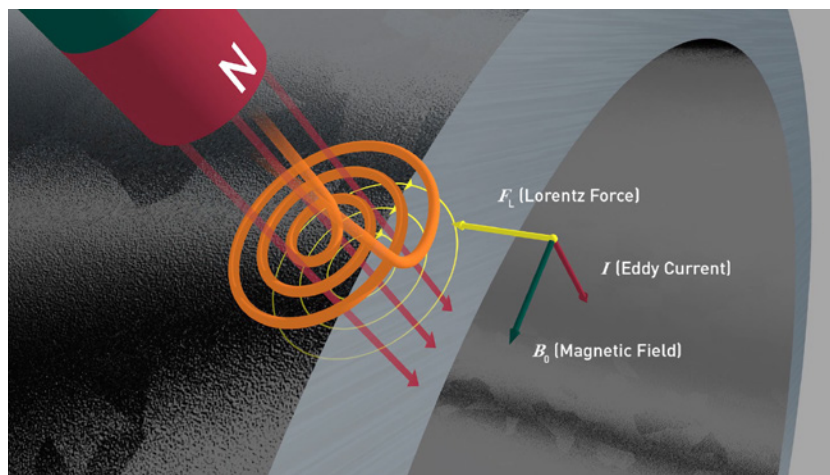

Fig. 4: Periodic Lorentz Forces

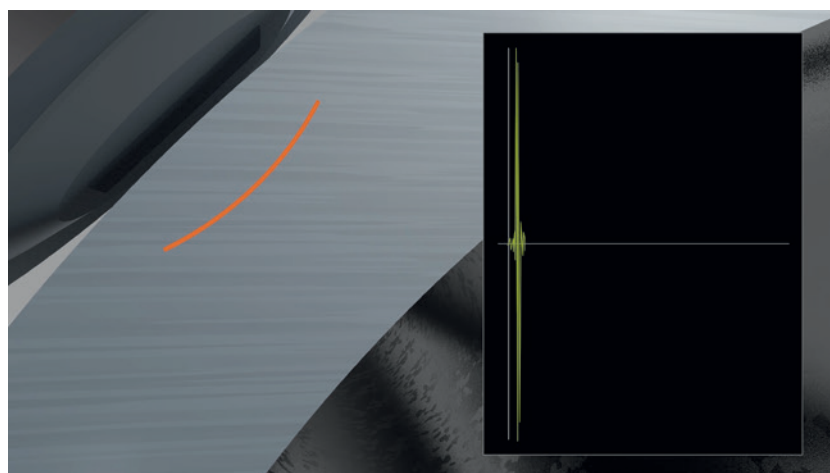
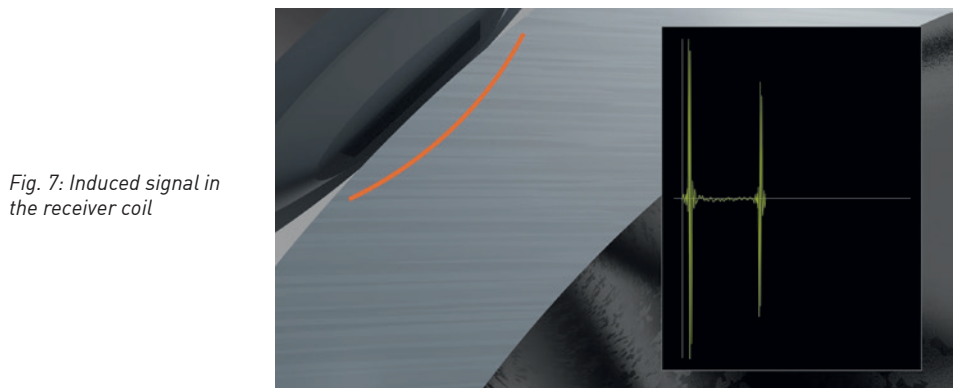
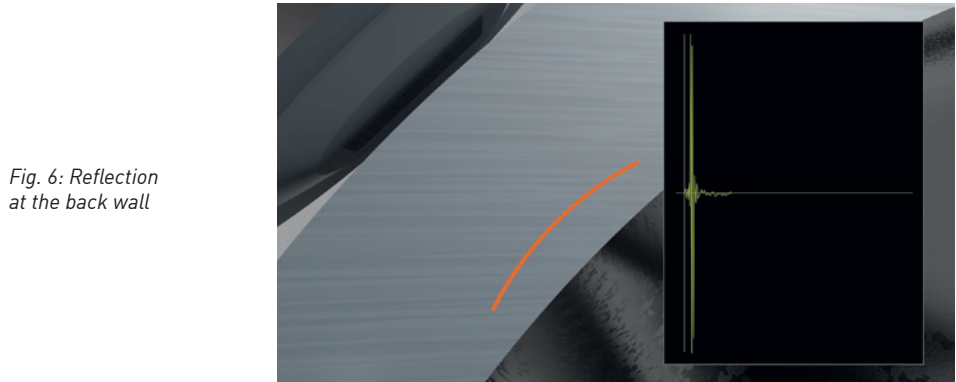

Fig. 5: Acoustic waves

The acoustic waves are reflected at the back wall (see Figure 6).

The back wall echoes induce signals in the receiver coil (see Figure 7). The wall thickness can be determined by the runtime of the back wall echo.



In the sensor system Ro 180 the generation of the required magnetic field is done by means of two electric coils whose magnetic flux is introduced through the probes into the test material. The magnetic reflux takes place via the rotor of the sensor system.

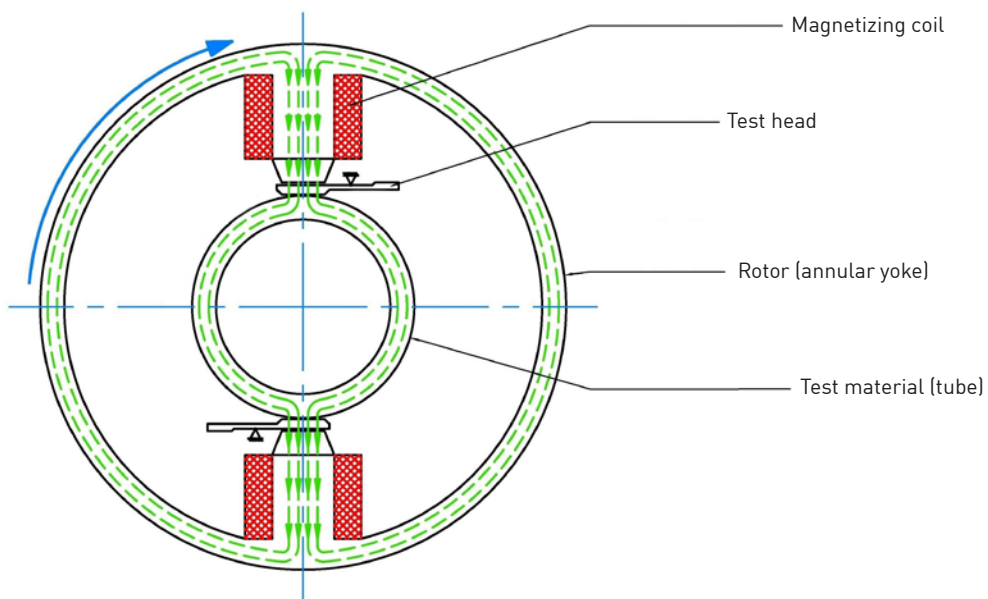

Fig. 8: Magnetic flux in the sensor system

Mechanical Construction

In general a complete CIRCOSON WT test system consists of:

- Testing and evaluation electronics
- Sensor system
- Cables and accessories

Testing and Evaluation Electronics

The testing and evaluation electronics consist of an Electronics cabinet (1) and a Power cabinet (2). The uniform hardware and software of the FOERSTER DS product platform as well as the integrated touch screen ensure easy handling.



Fig. 9: Testing and evaluation electronics for CIRCOSON® WT

Sensor System

Sensor system Ro 180: material diameter range from 20 to 180 mm

The operation side needs to be selected as right or left in the purchase order. The schematic structure of the sensor system is shown in the following figure.

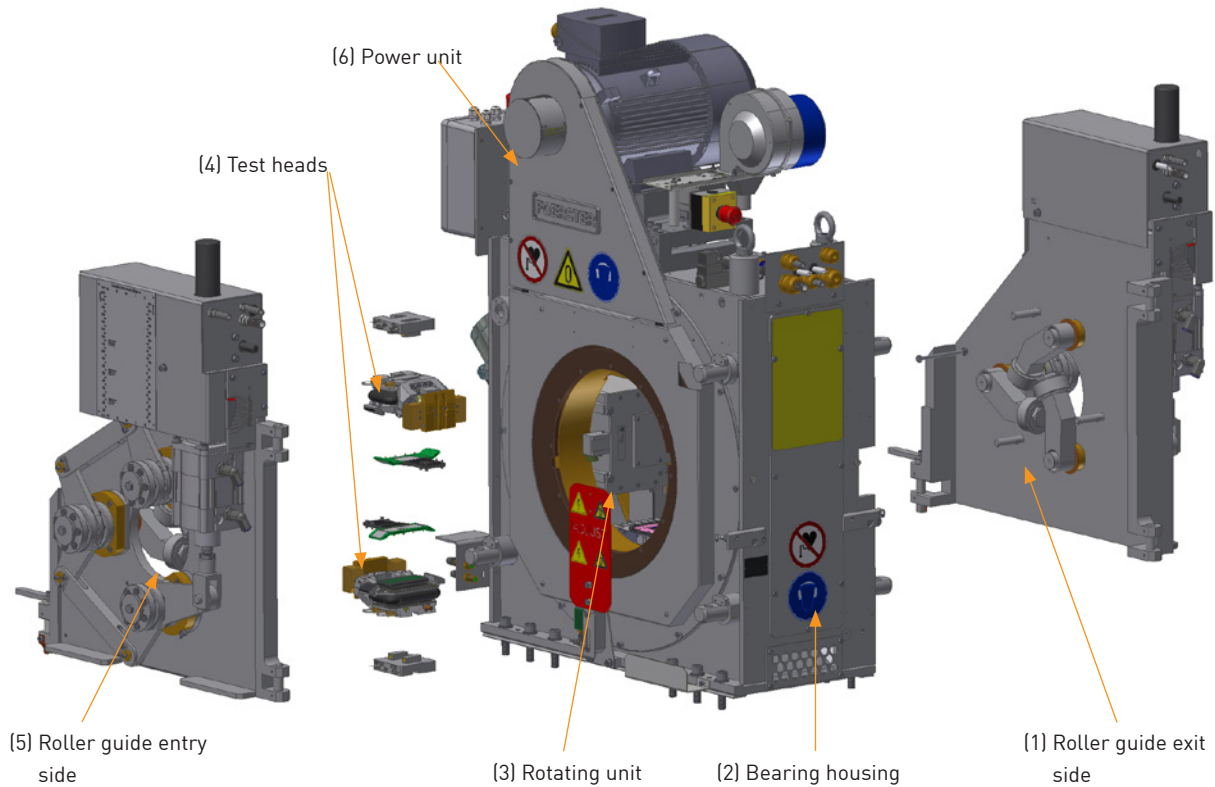

Fig. 10: Schematic construction of the sensor system

The sensor system consists of the following main components:

Rotating Head

The rotating head consists of a steel bearing housing and the rotating unit. The bearing housing contains removable cover plates on both sides. In addition, roller guides can be mounted on both sides. The drive takes place via a three-phase motor by means of a V-belt.

The signals recorded by the probes are transferred from the sensor system to the test electronics for evaluation. A terminal box is mounted on the connection side of the bearing housing, which provides the connection to the power cabinet for the control and drive signals.

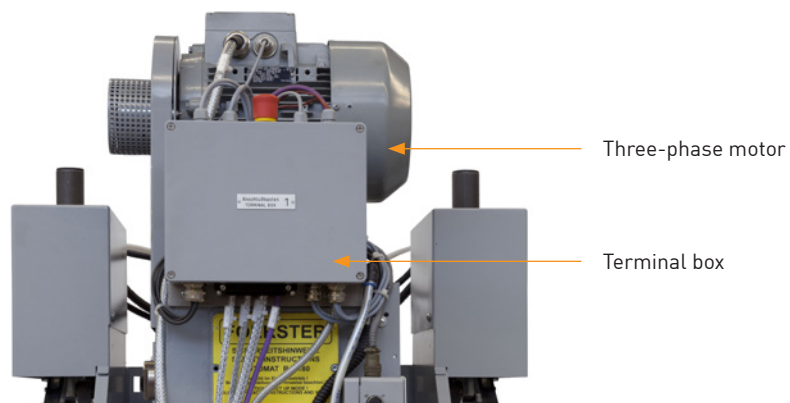

Fig. 11: Rotating head CIRCOSON® WT

Rotating Unit

The rotating unit consists of the following components:

- Rotor (1) consisting of non-magnetic bearing flanges and a ring that acts as a magnetic reflux
- Disc slip ring (13-path slip ring)
- Flange with brush blocks
- Two magnetizing coils (3)
- Two sensor electronics (2)

On the inlet side of the rotating unit is the drive pulley. At the circumference of the pulley 16 synchronizing magnets are mounted. During rotation, in a fixed Hall generator, they generate a pulse sequence that is directly proportional to the speed.

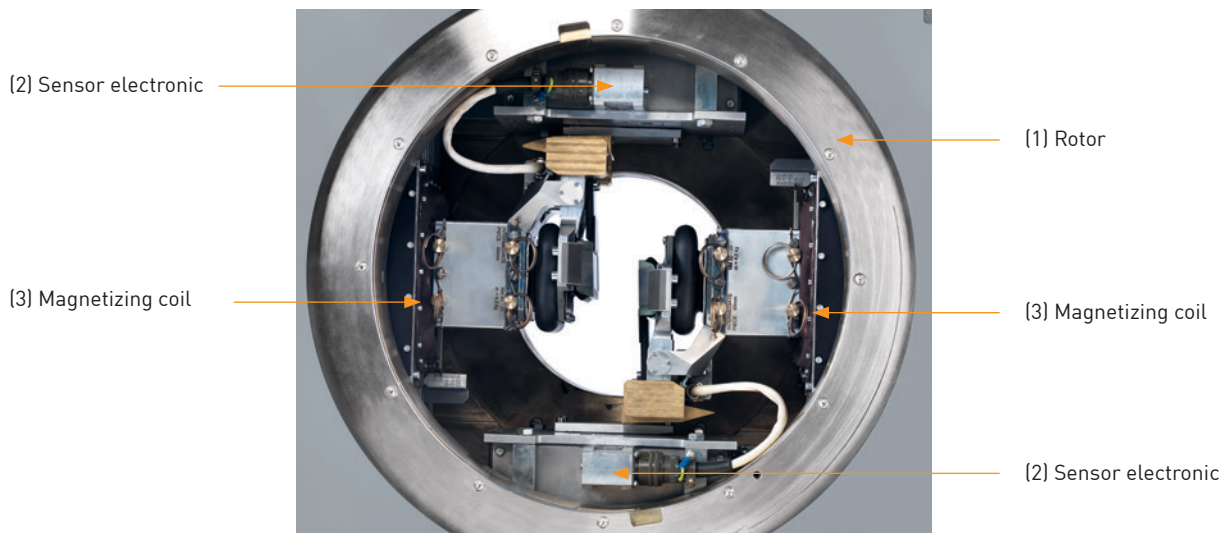

Fig. 12: Rotating unit

Disc Slip Ring and Brush Blocks

On the outlet side of the sensor system, a flange is mounted on the bearing housing. Four brush blocks with 6 carbon brushes each and additionally four brush blocks, each with one carbon brush, sit on the flange.

The rotating disk slip ring (13-path slip ring) is located behind the flange. The signals of the disc slip ring are transferred to the static side by the carbon brushes.



Fig. 13: Disc slip ring (left) and flange with brush blocks (right)

Spacers

The dimension adjustment takes place by adjusting the cores in the magnetization coils. This is done using an adjustment key for each of the two cores. In order to cover the entire diameter range from 20 to 180 mm, intermediate pieces (spacers) are installed between the core and the test head. Each pair of spacers can cover a diameter range of 40 mm. The gradation of the spacers can be adapted to customer requirements.



Fig. 14: Spacers

Test Heads

There are two different types of test heads that can be used in the Ro 180 sensor system.

- **8-channel test heads** (Wall Thickness Measurement and Lamination Testing)

The test heads have 8 EMAT probes that cover a range of 80 mm in the longitudinal direction without gaps. With these test heads a 100 % scan of the tube surface is possible. In addition, they can be used for lamination testing. In these test heads, the probes are protected by a wear-resistant protective plate, which can be replaced. Various materials are available for these wear plates. The wear plates must be changed at regular intervals. Their lifetime depends on variables such as the test speed, the surface and the end condition of the test material.

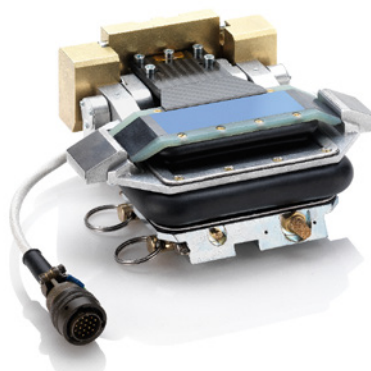

Fig. 15: 8-channel test head

▪ **4-channel test heads** (only wall thickness measurement)

These test heads have 4 round EMAT probes, each embedded in a wear-resistant ceramic material. The ceramic material is glued into the carbide plated test shoe. The total track of this test head is also 80 mm, but you cannot reach a 100% coverage of the tube surface with these test heads, because there are gaps between the individual probes. Nevertheless, even with these heads, e.g. a wall thickness reduction of 25.4 mm x 25.4 mm (1" x 1") can be reliably detected and measured.



Fig. 16: 4-channel test head

Both types of test heads consist of:

- Test shoe (1)
- Test head cable(2)
- Base (3)

Via the base, the magnetic flux is introduced through the EMAT probes into the test material. The bases of both test head types are identical.

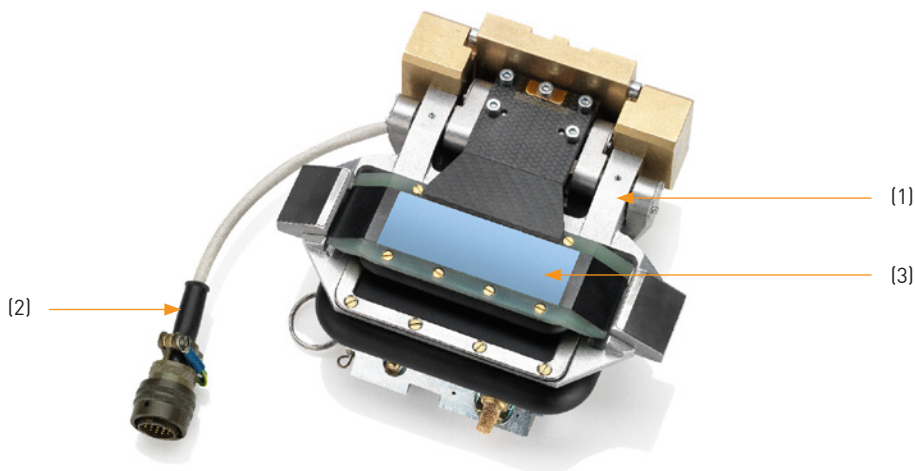

Fig. 17: Components of the test head

Roller Guides (optional)

Roller guides are mounted on the inlet and outlet side of the sensor system for exact guidance of the test material within the rotating unit. These roller guides ensure vibration-free, precise material guidance through the sensor system.

The roller guide is automatically adjusted to the test material diameter by the positioning unit as specified in the operating software. The set value can be read on the scale on the operating page. The roller guides can be swung out for dimension change or during maintenance.

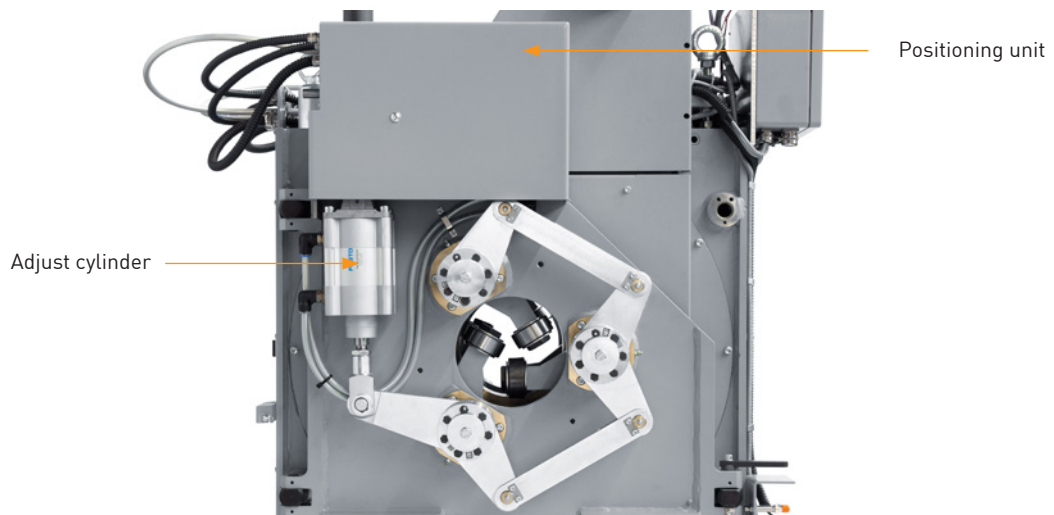

Fig. 18: Roller guides

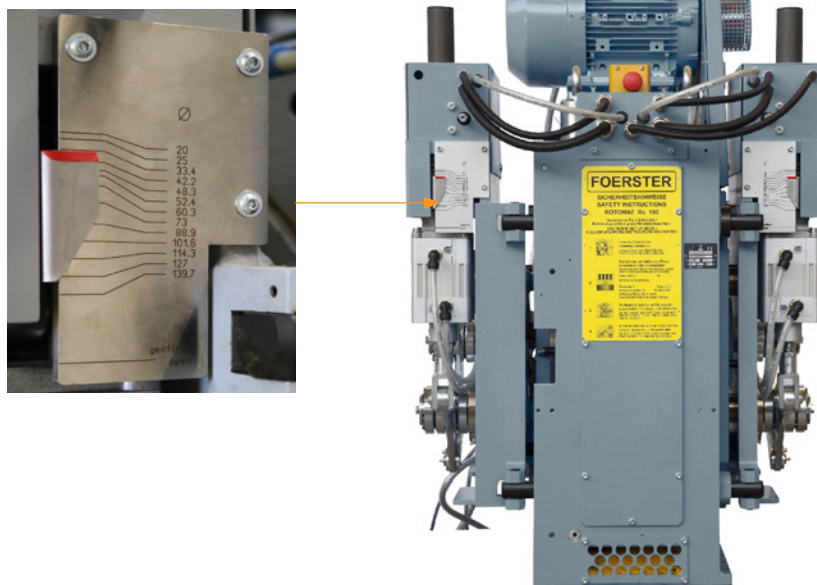

Fig. 19: Scale

Suction Connection (optional)

Optionally, suction connections can be mounted on one or both sides of the rotating head. They can then be connected to a suction unit to collect dirt and scale. This is particularly recommended for test material with a hot-rolled surface and a high degree of contamination.

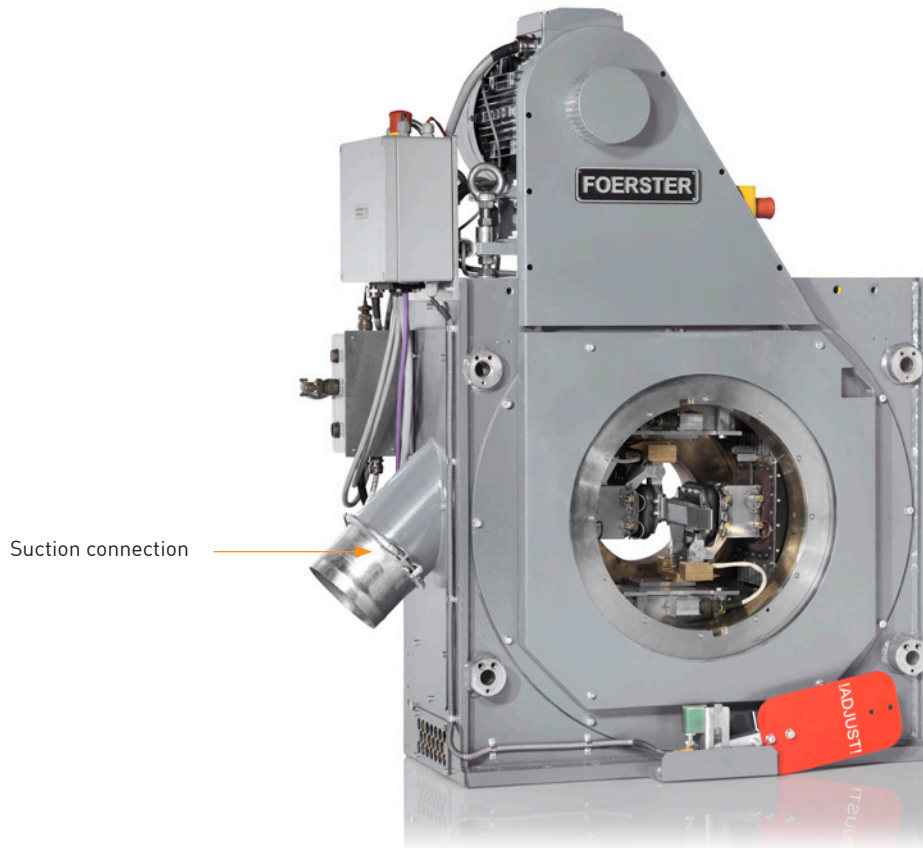

Fig. 20: CIRCOSON WT with suction connection

Specifications of the Test Material

Specifications of the Test Material	
Test Material	Ferromagnetic seamless steel tubes
Diameter Range of Test Material	<ul style="list-style-type: none"> ▪ 20 mm to 180 mm for wall thickness measurement ▪ 60 mm to 180 mm for lamination testing
Diameter Tolerance	<ul style="list-style-type: none"> ▪ For tube diameters ≤ 80 mm: ± 0.8 mm ▪ For tube diameters > 80 mm: ± 1 % of the nominal diameter
Ovality	The Ovality is included in the diameter tolerance
Deviation from Straightness	Maximum deviation from straightness 2.5 mm/m with regard to the tangent, not more than 15 mm over the entire tube length
Ratio of Diameter to Wall Thickness	$\geq 3 : 1$
Wall Thickness of the Test Material	<ul style="list-style-type: none"> ▪ For wall thickness measurement: 5 mm to 25 mm. The possibility for measurement of wall thickness outside of this range needs to be clarified with customer material in advance. ▪ For lamination testing: 7 mm to 15 mm, for wall thicknesses outside of this range, the possibility of a lamination testing of the customer material needs to be clarified in advance.
Surface Condition	<ul style="list-style-type: none"> ▪ Bright or hot-rolled ▪ Free from loose scale ▪ Free from protruding burrs, scabs, chips and spicules ▪ Free from liquid, oil and grease ▪ Concave faults with a width of more than 5 mm and a depth larger than 1 mm are not permitted
Temperature of the Test Material	<ul style="list-style-type: none"> ▪ +5 °C to +80 °C ▪ It needs to be considered that the speed of sound usually depends on the temperature of the tube and that larger temperature deviations can thus lead to increased measurement inaccuracies of the wall thickness.
Condition of the Ends	<ul style="list-style-type: none"> ▪ Both ends free from protruding burrs, scabs, chips and spicules ▪ Cut or sawn in a right angle to the axis ▪ Tube free from chips on the inside as well as the outside, free from protruding spicules ▪ No deformation of the cross section
Form of the Ends	<ul style="list-style-type: none"> ▪ Plain ends, no compressed ends, no threads, no protective covers, no upset ends

Transport of the Test Material

In General

Transport should be as steady and vibration-free as possible. Tremors resulting from the running up and down of tube ends on and off the rollers of the roller conveyor and from the pressure rollers making contact with the tube can lead to noise signals and are to be avoided.

For an optimal use of the system, the throughput speed must be continuously adjustable in order to adapt it to the diameter-dependent rotational speed of the rotating head.

From entry of the test piece into the rotating head to the exit from the marking position, the throughput speed should be constant within the entire used speed range with a maximum deviation of 5 % from the fixed speed (exception: dipping mode, see below). The precision of various test results and defect marking directly depend on the speed constancy. If the constancy cannot be achieved precisely enough, a continuously updated speed information (determined with an encoder wheel or optical systems) needs to be provided.

In order to be able to easily set the test instrument, the roller conveyor must be reversible.

Guidance Accuracy

Curvature, ovality, diameter tolerance and guidance eccentricity must be within the circle diameter D1 (max. D2), see chapter „Admissible Tolerance of Test Material“. All burrs, scabs, spicules and other elevations protruding from the surface may not exceed 1 mm to prevent the sensor system from being damaged.

Test Speed

The test speed depends on the tube diameter because of the maximal admissible values for the rotational speed of the rotating head (1200 rpm) and the circumferential speed of the probes. With regard to the wear of the bearings and the test shoes, 1000 rpm or 6 m/s should not be exceeded. The test speed diagram (see chapter „Wall Thickness Measurement and Lamination Testing“) is based on these values and on an effective test head length of 80 mm. This means that per rotation of the rotating head a test piece feed of 160 mm is possible minus the speed tolerance of the transport system (typically 5 %) and the rotational speed tolerance of the rotating head (typically 3 %).

For the automatic probe adjust for lamination testing, the roller conveyor must allow for a quite slow run-through of the test tube. Thereby, the transport must also be steady under adherence of the given speed (tolerance: $\pm 20\%$). If the adjust defect is, for example, a lamination with the dimensions 6 mm (circumference) x 25 mm (longitudinal direction), a maximum adjust speed of 0.1 m/s is necessary. When using shorter defects in throughput direction for the adjust, the maximum adjust speed goes down further. Therefore, for the adjust of an FBH 6.3 mm, a maximum adjust speed of 0.03 m/s is permitted.

Admissible Tolerance of Test Material

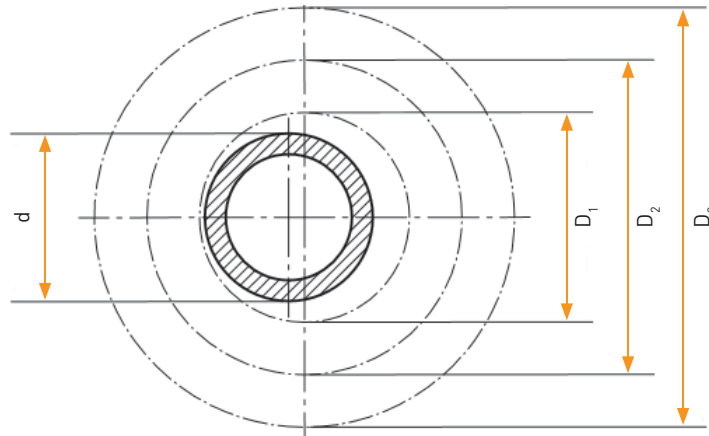

d [mm]	D ₁ [mm]	D ₂ [mm]	D ₃ [mm]
	Optimum test results can be anticipated if the test material lies within this tolerance limit	Restricted inspection is possible when specimen's position is within these tolerances	Serious damage to the equipment will result if these values are exceeded
Nominal diameter of test material at Ro 180	Tolerance limits		Maximum limit
20 - 60	d + 2,0	d + 5,0	d + 12,0
60 - 100	d + 3,0	d + 5,0	d + 12,0
100 - 140	d + 4,0	d + 5,0	d + 12,0
140 - 180	d + 4,0	d + 5,0	d + 12,0
Deviation of the test material at the point of inspection resulting from center deviation, material tolerances and curvature etc. is permissible, as long as every point on the test material surface remains within a given tolerance range.			

Wall Thickness Measurement and Lamination Testing

Noise Level

The accuracy of the wall thickness measurement and the sensitivity of the lamination testing depend decisively on the noise level of the ultrasonic signal and the surface condition. The noise level itself, on the other hand, depends on the surface condition, material properties such as, for example, grain size and the mechanical guidance and motion of the test material through the rotating head.

For a reliable automatic measurement or test, the signal-to-noise ratio needs to be at least 3:1 and the noise level needs to be observed with regard to the corresponding use signal. In case of the wall thickness measurement, this signal is the back wall echo, which is supposed to be evaluated and in case of lamination testing, it is the defect signal of the minimum reference defect that is to be detected.

For guidance and transport see section 2. Tremors can cause pseudo signals and an unsteady transport of the test piece can increase the general noise level.

The accuracy of the wall thickness measurement and the sensitivity of the lamination testing cannot be reproduced for certain or are more or less strongly limited in the area of burrs, shells, spears and sunken spots. Depending on the type of protruding part, pseudo signals cannot be excluded.

Material with a higher content of chrome can show a more or less strong appearance of chromium dioxide on the surface. This can lead to very large fluctuations in the amplitude of the ultrasound waves and is often accompanied by a strong mode conversion. This is generally also the case if the scale on the surface has strong magnetostrictive properties.

Under these circumstances, the accuracy of the wall thickness measurement and the sensitivity of the lamination testing can be severely restricted, or, in the most extreme case, even be impossible.

In general, scale plates on the material surface can cause reflections of the ultrasound that will become noticeable as noises in the ultrasound signal. This means that because of this, lamination testing may be restricted or even impossible. Likewise, there may be restrictions for wall thickness measurement and in the most extreme case, it can also become impossible.

Wall Thickness Measurement

- **Measurable wall thickness range (nominal):**

5 mm to 25 mm, wall thickness deviations of up to at least $\pm 15\%$ of the nominal wall thickness can still be measured. For wall thicknesses <5 mm and >25 mm the possibility of measurement needs to be confirmed on customer material beforehand.

- **Accuracy of the Wall Thickness Measurement:**

$\pm 0,05$ mm (± 50 μ m). This value requires the exact knowledge of the speed of sound. The device must be set with an appropriate calibration piece made of the same material.

- **Resolution of the Wall Thickness Measurement: : 0,001 mm (1 μ m)**

▪ **Reference Defect of the Wall Thickness Measurement:**

25 mm x 25 mm, depth 10 % or 12.5 % of the nominal wall thickness, applied (e.g. with spark erosion) from the inner wall of the tube. This defect can be used to check the accuracy of the wall thickness measurement, as long as the remaining rest wall is constant over an area of 25 mm x 25 mm (permitted fluctuation of the rest wall is $\pm 20 \mu\text{m}$). The application of this reference defect may require a processing of the tube piece on the inside and outside. The reference defect will be detected dynamically with every run and its wall thickness will be measured within the above mentioned accuracy (applies for 8-channel test heads and 4-channel test heads). During this, the speed may not exceed the maximum speed determined with the speed diagram.

▪ **Coverage of the Tube Surface:**

Using the **8-channel test head** allows for a 100 % coverage if the maximum speed as per the speed diagram is used. Slower speeds lead to a coverage of over 100 %. If fluctuations in the line speed and in the rotational speed of the rotating head are to be taken into account, the maximum test speed from the diagram needs to be reduced accordingly in order to still be able to ensure a 100 % coverage.

The **4-channel test heads** have gaps between the individual probes. This leads to a coverage of approximately 50 % of the tube surface if the maximum speed as per the speed diagram is used. Fluctuations of the line speed and the rotational speed of the rotating head can be taken into account as described above. Note: Due to the layout of the test heads, in this case, it is not easily possible to achieve a 100 % coverage.

▪ **Speed Diagram:**

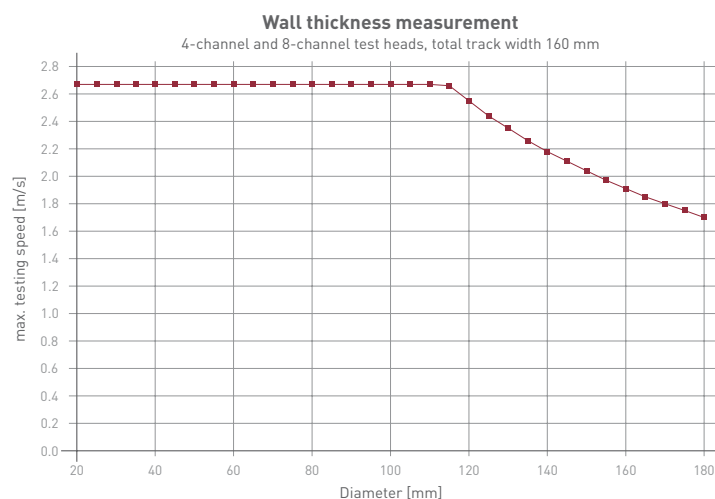

Lamination Testing (according to DIN EN ISO 10893-8)

▪ **Diameter Range: :**

60 mm to 180 mm

▪ **Wall Thickness Range:**

7 mm to 15 mm, for wall thicknesses (WD) outside of this range, the possibility of lamination testing on the customer material needs to be clarified in advance.

▪ **Reference Defect:**

Lamination 6 mm (in circumferential direction) x 25 mm (in longitudinal direction), depth (t): $WD/4 \leq t \leq WD/2$, typically: $t=WD/2$. The laminations are to be applied from the inside of the tube. This lamination is detected dynamically during each run, as long as the speed is not higher than the maximum value for the lamination testing defined in the speed diagram. Detecting the defect means that at least one probe registers the defect with an amplitude that is above the predefined defect threshold. It is usually not to be expected that the defect amplitude of the reference defect delivers the same value in multiple runs or is subject to just small fluctuations. In case of smaller defects (e.g. FBH), a fluctuation by a factor of two or more is to be expected due to the size ratios of probe and defect. If a smaller defect than the reference defect mentioned above can be used for the dynamic detection needs to be examined in each individual case.

▪ **Adjust Defect:**

FBH 6.3 mm, depth: $WD/4 \leq t \leq WD/2$, typically: $t=WD/2$, to be applied from the inside of the tube. This defect can be used for the static setting of the sensitivity of the CIRCOSON WT according to DIN EN ISO 10893-8.

▪ **Speed Diagram:**

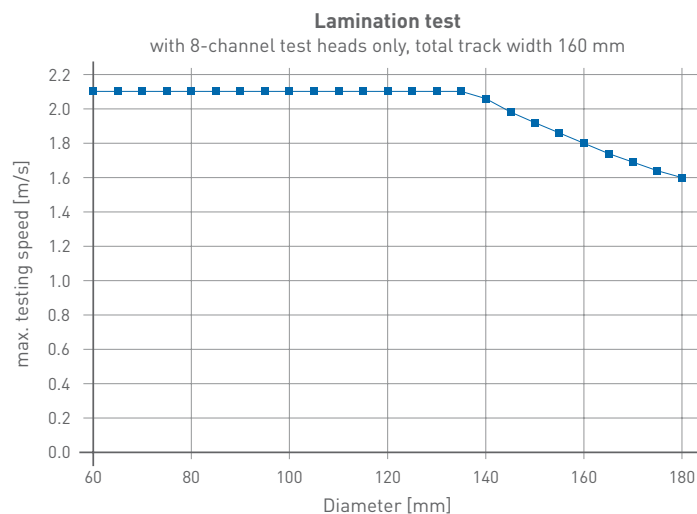

Lamination testing and wall thickness measurement can be performed simultaneously. The maximum test speed that shall be adhered to is the speed according to the diagram for lamination testing.

Acceptance Specification

For the acceptance, the buyer provides two sample test pieces of each smallest, middle and largest diameter of which one of each serves for the detection of the specifically detectable minimum defect and which is not returned. The second piece of each, on the other hand, is equipped with the agreed reference defects and serves as binding test tube for the acceptance of the test instrument at the IFR as well as at the plant of the customer after the completion of the installation on-site. The test tubes of this second binding set can also be equipped with an adjust defect for lamination testing.

The test instrument is considered accepted when the test results, detected and registered in our house, are reproduced in a comparable quality at the plant of our customer using the same test tubes.

The guarantee for the detectability of the defects is exclusively based on the material of the test tubes, their surface condition and magnetic inhomogeneities and the applied test defects. We ask for the sample test pieces to have a length of 3 to 6 m depending on which shortest tube length can be transported by the mechanics (including entry and exit sections). If, in exceptional cases, the customer is unable to provide the sample test pieces, the IFR is willing to obtain them at the customer's expense.

Assembly, commissioning and acceptance of the delivered units under the supervision or with the assistance of qualified personnel from IFR is precondition for all warranties of IFR.

Requirements for the Operation of the Test Instrument

Specifications	
Electromagnetic Compatibility (EMC)	<p>Our instruments and systems comply with the EMC-Guideline 2004/108/EG (electromagnetic compatibility) as well as the corresponding European Norms EN 61326-1.</p> <p>If electromagnetic disturbances occur at the installation site which exceed the thresholds defined by EN 61326-1, additional measures could become necessary that may go beyond the scope of the submitted offer.</p>
Electrical Supply	<p>Three-phase supply 3*400 V ± 10 %, 50/60 Hz with grounded and fully loadable neutral, with PE wire.</p> <p>In case of different voltages or missing neutral, additional transformers need to be provided (supplied by the customer).</p> <p>Power consumption: max. 19 kVA</p>
Compressed Air Supply	<p>Constant operating pressure between 5 and 7 bar (gauge pressure), low oil and water content.</p> <p>Air consumption at 5 bar gauge pressure:</p> <ul style="list-style-type: none"> ▪ For controlled roller guides at the entry and exit: approx. 10 Nm³ / h ▪ For 1-channel color marking: <ul style="list-style-type: none"> ▪ Spray air: approx. 2,6 Nm³ / h ▪ Blowing Air: approx. 0,12 Nm³ / h
Ambient Conditions	<ul style="list-style-type: none"> ▪ Relative humidity: 85 % ▪ Operating temperature: 5 to 45 °C

Performance Data

Testing

- **When using 8-channel test heads:**

Complete test of tubes over the entire length for laminations and measurement of the wall thickness except for untested ends.

- **When using 4-channel test heads:**

Measurement of the wall thickness over the entire tube length except for untested ends. The coverage of the surface is usually more than 50 %.

Changeover Times

- approx. 3 minutes if the spacers do not need to be changed,
- approx. 10 minutes if the spacers also need to be changed.

The accumulated scale in the test instrument must be removed (suctioned off).

In case of a high scale accumulation, high throughput and short conversion times, a permanently installed extraction system is necessary. Corresponding exhaustor connection piece can be installed on the sensor system for an additional charge.

Untested Ends

The untested ends depend on the condition of the ends and the guidance of the test material. The following values apply to good end conditions (meaning no spurs or chips, no bent ends) and good guidance of the test material (see 2. Transport of the Test Piece).

- At a constant test speed up to 2.6 m/s: typically 200 mm
- At a constant test speed up to 1.0 m/s: typically 100 mm

During dipping mode (speed reduction upon entry of the material):

- approx. 10 mm to approx. 50 mm, depending on the speed reduction, the accuracy of the clock pulse, the entry light barrier and the angularity of the saw cut at the ends of the tube.

Marking Duration of the Color Marking

At least 25 ms. The accuracy of the marking of the defect depends on the precision of the clock pulse, the maintenance condition of the marking guns and the distance of the marking gun to the material.

The marking is carried out according to longitudinal position.

Depending on the requirements for the marking accuracy, it is necessary to consider further suitable equipment (precise clock pulse and light barriers, adjustable marking guns).

Further Technical Data

Parameters of the Ultrasound System

Specifications	
Type of ultrasound waves	Shear waves (transversal waves)
Frequency of the ultrasound excitation	approx. 5 MHz
Measurement principal	Impulse-Echo-Method
Pulse repetition frequency	max. 2 x 32 kHz, multiplexed over all maximally 16 channels. In general, it is possible to operate 2 channels simultaneously.
Pulse repetition frequency per channel	max. 4 KHz
Magnetization	Rotating DC field

Test Heads

Specifications	
Number of test heads	Two, installed in circumferential direction shifted by 180°
Number of EMAT probes per test head	8 or 4
Track width	80 mm per test head
Number of test channels	16 (when using 4-channel test heads only 8 of them are used)
Layout of the 8-channel test heads	8 EMAT probes with an effective length of 10 mm in throughput direction, in gapless arrangement
Layout of the 4-channel test heads	4 EMAT probes with an effective length of approx. 10 mm each in throughput direction; between the individual probes are gaps of approx. 10 mm; the distance from one probe center to the next is 20 mm.

Rotating Head

Specifications	
Dimensions	see dimension sheets
Weight Sensor System	approx. 800 kg (without roller guides)
Weight Roller Guides (Entry Side)	approx. 140 kg
Weight Roller Guides (Exit Side)	approx. 147 kg
Deceleration Time	<p>The deceleration time of the sensor system depends on the rotational speed, how it was turned off and the condition of the bearings. In case of a good condition of the bearings, the following values apply:</p> <ul style="list-style-type: none"> ▪ Deceleration time with braking (turning off on the touch panel or with the EMERGENCY STOP): approx. 60 – 65 seconds (at 1000 rpm) ▪ Deceleration time without braking (e.g. when turning off the main switch): approx. 250 – 300 seconds (at 1000 rpm)

Noise Emissions

Specifications	
Maximum sound pressure level	<ul style="list-style-type: none"> ▪ 82 dB(A); rotating head outside of the test section and without test material ▪ 88 dB(A); rotating head in the test section and with test material <p>(These values were measured at a distance of 1 m from the machine surface, 1.6 m above the ground, at the maximum rotational speed of 1000 rpm.)</p> <p>The measured values depend on the individual layout of the test section and the surroundings. The operator must measure the sound pressure level. In general, the sound pressure levels are lower at the working station, since the main emission is towards the roller conveyor.</p>

Dimensions

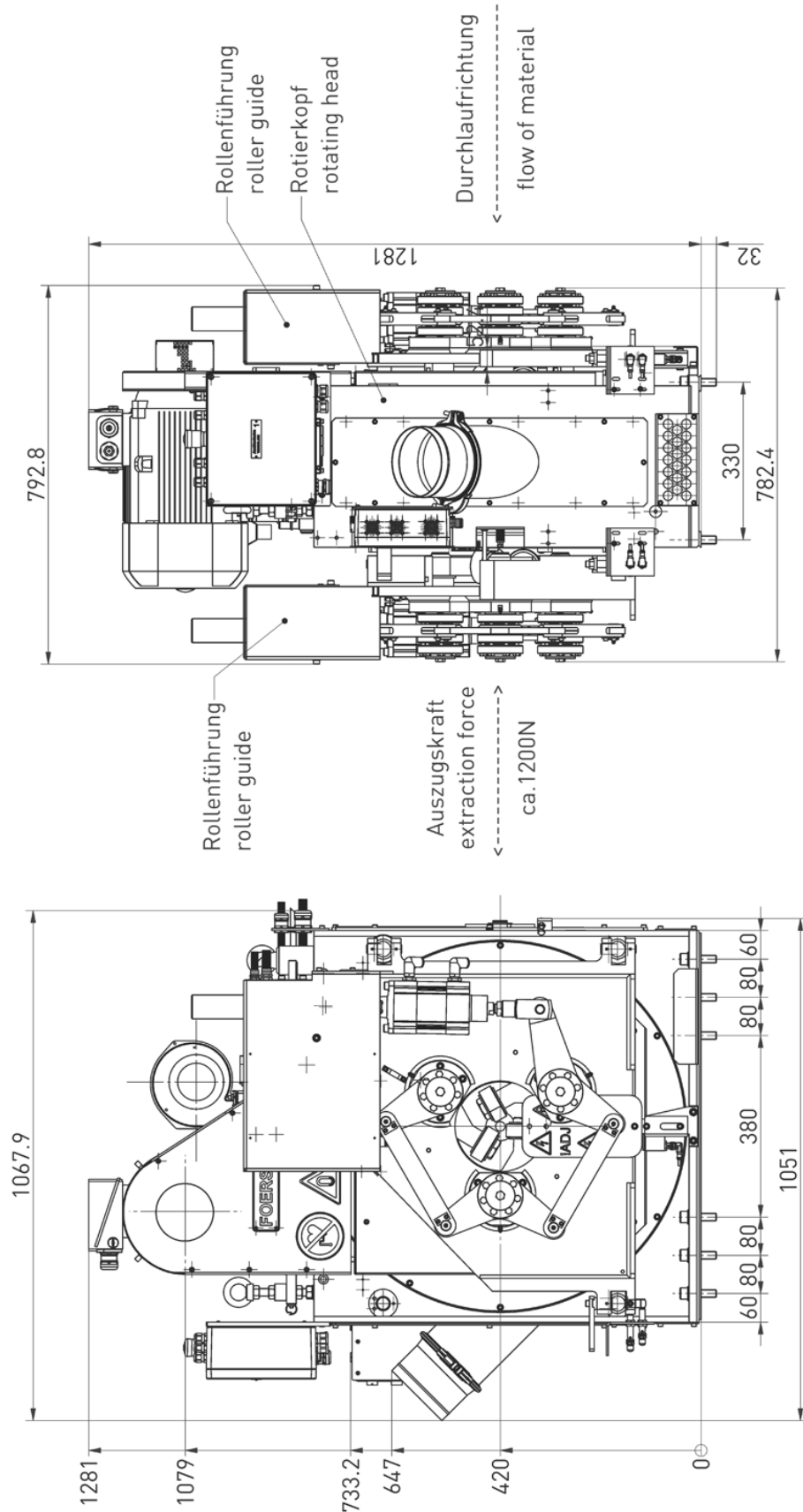

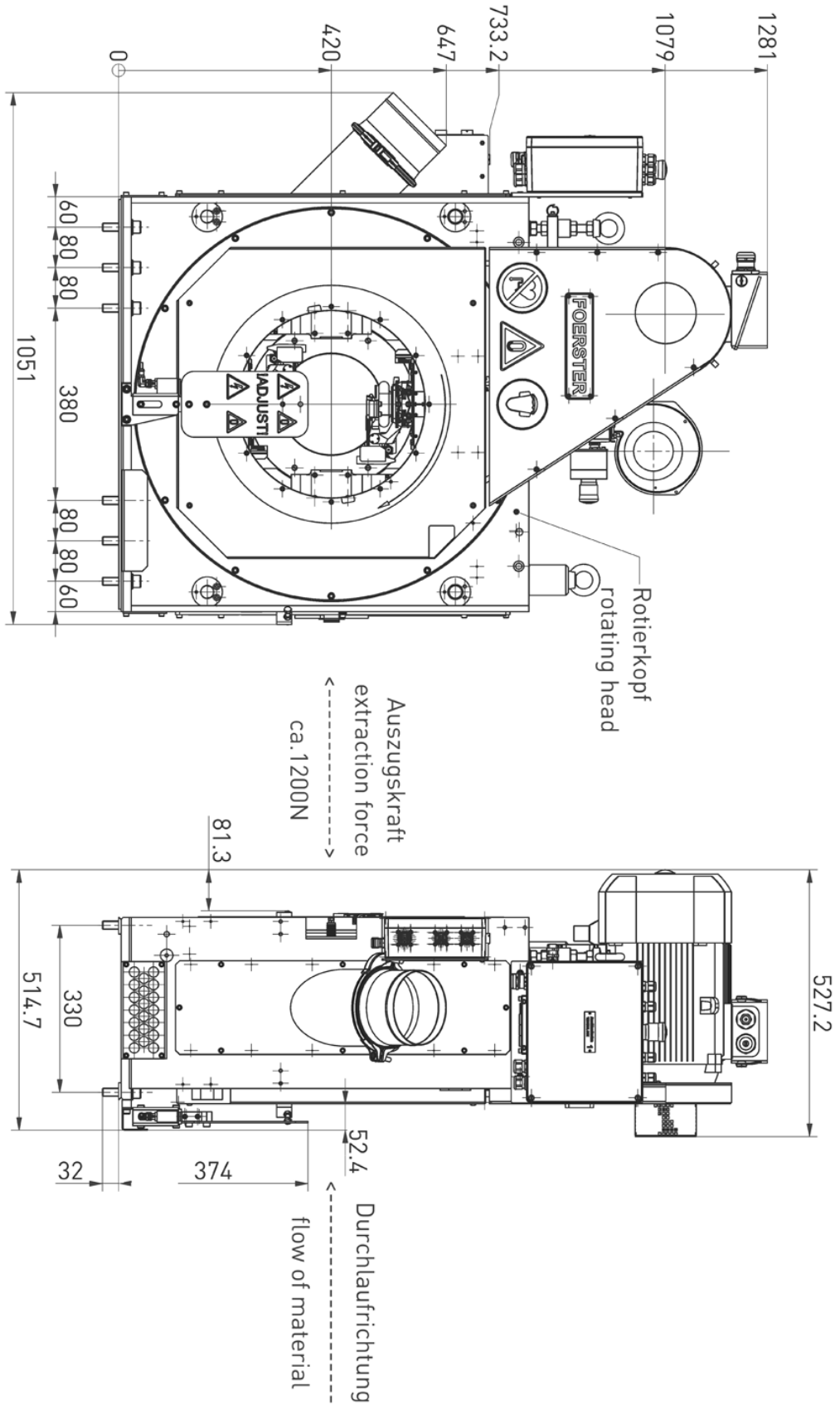

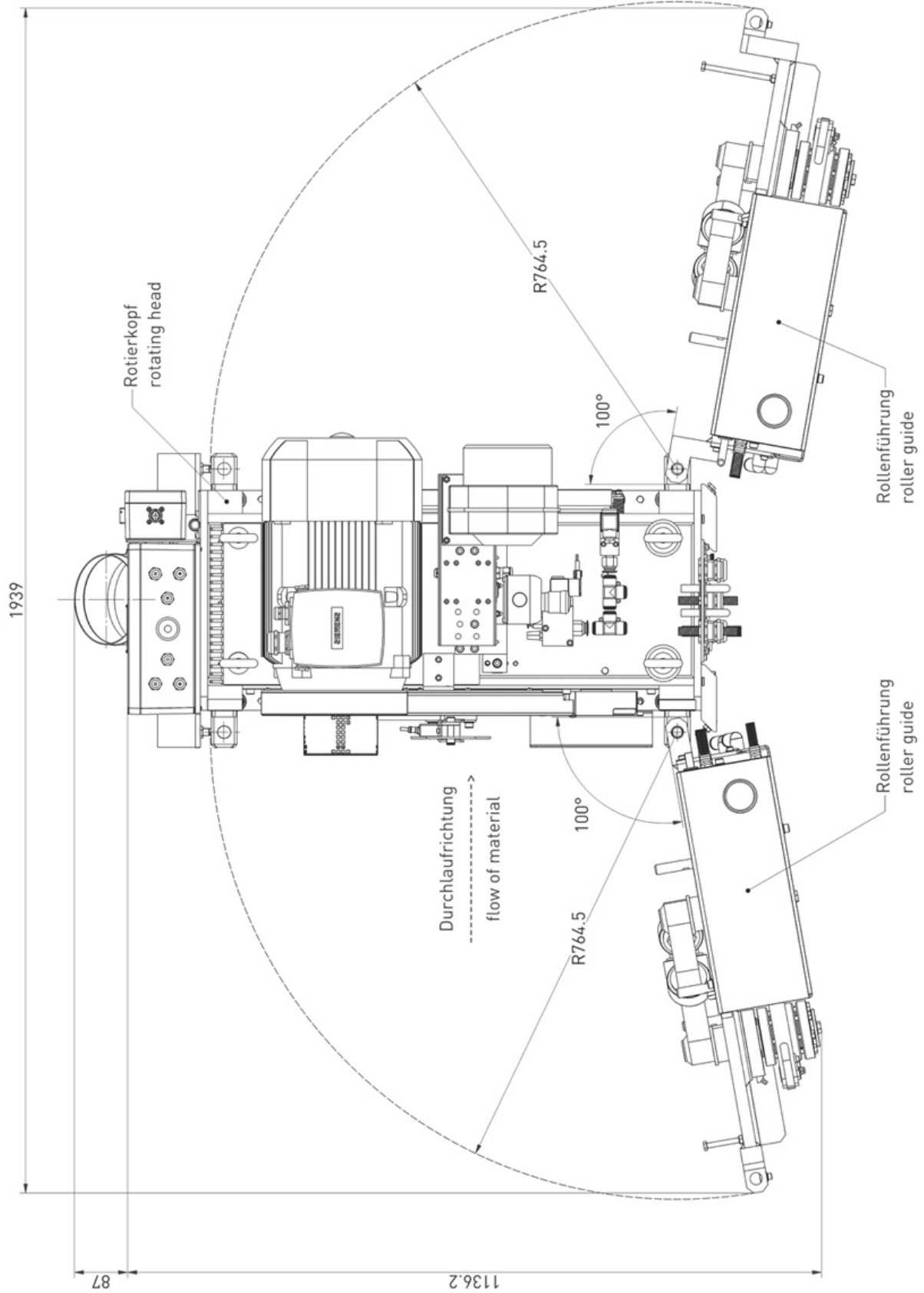

Worldwide Sales and Support Offices



Headquarters

- Institut Dr. Foerster GmbH & Co. KG, Deutschland

Subsidiaries

- Magnetische Pruefanlagen GmbH, Germany
- FOERSTER France SAS, France
- FOERSTER U.K. Limited, United Kingdom
- FOERSTER Italia S.r.l., Italy
- FOERSTER Russland AO, Russia
- FOERSTER Tecom, s.r.o., Czech Republic
- FOERSTER (Shanghai) NDT Instruments Co., Ltd., China
- FOERSTER Japan Limited, Japan
- NDT Instruments Pte Ltd, Singapore
- FOERSTER Instruments Inc., USA

The FOERSTER Group is being represented by subsidiaries and representatives in over 60 countries - worldwide.

Institut Dr. Foerster GmbH & Co. KG Division Test Systems

In Laisen 70
72766 Reutlingen
Germany
+49 7121 140 0
info@foerstergroup.de

